

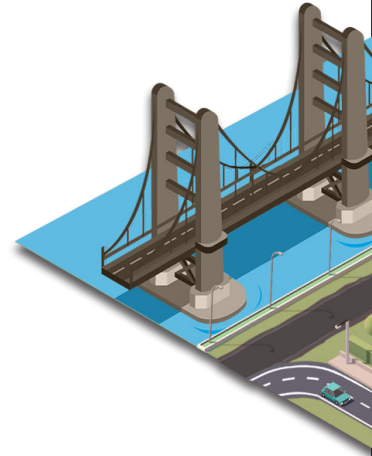

THE BETWEEN THE WORLD
BARRETT & THE WEATHER
COMPANY SINCE 1928



Proven performance over time is the best indicator of quality when it comes to roofing & waterproofing systems. The Barrett Company has been providing top quality materials & systems for roofing & waterproofing since 1928.

Our hands-on experience & personalized attention to each project has proven itself to be an invaluable asset that is readily available to architects, engineers, contractors, and builders alike.



- 1 Plaza Decks
- 2 Protected Membrane Roofs (IRMA®)
- 3 Green Roofs
- 4 Built-Up Roofs
- 5 Cool Roofs
- 6 Foundation Waterproofing
- 7 Under Tile Waterproofing
- 8 Bridge Decks
- 9 Parking Decks
- 10 Pool Decks
- 11 Planters
- 12 Stadiums
- 13 Balconies
- 14 Tunnels

Why

Table of Contents

- Intro/Applications..... 1**
- History/Why Barrett?..... 3**
- RamTough 250..... 5**
Hot Fluid Applied Rubberized Asphalt Roofing & Waterproofing System
- Black Pearl®..... 9**
Cold Applied Rubberized Asphalt Roofing & Waterproofing System
- RamTough KLB-100..... 13**
Hot Applied SEBS Modified Asphalt Elastomeric Built-Up Roofing System
- HyppoCoat GC..... 17**
Single Component Fluid Applied Elastomeric Waterproofing Membrane
- RamProof GC..... 21**
Single Component Fluid Applied Elastomeric Rubberized Asphalt Waterproofing Membrane
- HyppoCoat 100..... 25**
Hybrid Polyurea/Polyurethane Balcony Deck Waterproofing System
- HyppoCoat 250..... 29**
Water-Catalyzed Polyurethane Trafficable Deck Waterproofing System
- Ram Cold Tar® Plus..... 33**
Single Component Fluid Applied Elastomeric Roof Restoration Coating
- Ram QuikFlash® PMMA..... 37**
Cold Fluid Applied Polymethyl Methacrylate Roofing Membrane & Flashing Systems
- Greenroof-Roofscapes®..... 43**
Complete Waterproofing Systems for Green Roof + Landscape Assemblies
- Below-Grade Waterproofing..... 47**
- Products List..... 49**
 - Liquid Membranes.....49
 - Fabrics & Sheets.....51
 - Flashings & Accessories.....54
 - Preformed Drainage.....57
 - Retention & Aeration.....59
 - Root Barriers.....61
 - Coatings & Mastics.....63
 - Recycled Content.....66
- Insulation & Pavers..... 67**
- Warranties..... 69**
- Resources..... 71**

Preserving the past with experience & the future with technology.

Barrett’s leadership in roofing & waterproofing dates back more than three-quarters of a century. Since the early days of built-up roof construction, Barrett has become a pioneer in the field, improving its materials, application methods, and facilities for service stride-for-stride with the advance of the building industry as a whole.

Today, the Barrett Company has become a national leader in evolving bitumen modification technology and the design of high-performance waterproofing, built-up roofing systems, and vegetated roofs.

The time-proven performance of our company and our superior products sets us apart from the giant “everything to everybody” suppliers. Our direct, “hands-on” experience, with personalized attention to each project, is an asset that provides true value and is always readily available to all architects, engineers, contractors, and builders alike.

With nearly a century of experience providing top quality roofing & waterproofing systems for leading architects, engineers, and builders of modern structures, we can say with confidence that no finer materials of this character are obtainable than those bearing the Barrett label.



PICTURED: “Barrett’s Handbook on Roofing & Waterproofing” (©1896)

Barrett?

KNOWLEDGE

Barrett's understanding & acquired knowledge of roofing basics & material engineering concepts, from asphalt polymerization to felt condensing techniques; from workable flashing techniques to CAD detailing, is applied to each and every project by a Registered Roof Consultant or a corporate principle.

EXPERIENCE

With over ninety years of diverse roofing & waterproofing applications, countless material & roof analyses accumulated through both practical, "hands-on" experience & theoretical laboratory pursuits, Barrett has developed a realm of experience, particularly in the waterproofing and reroofing fields, that is unique and unequaled by other manufacturers.

TRUST

Roofing performance promises are easy to make, but hard to deliver. Almost all roofing material manufacturers advertise that they offer the "best" or "ultimate" systems to meet every need of every customer. Our approach focuses on the needs of each customer individually & ensuring they know exactly what they are getting.

VALUE

Every designer and specifier has the right to expect excellence with service, as well as excellence in product & systems knowledge from their suppliers. Every building owner has the right to expect a leak-free, watertight system that will stay that way beyond the warranty period. Our job is to provide the best possible system for each application. To do that, we must manufacture a variety of systems and test them to ensure they can all exceed certain levels of performance & protection.

MADE IN THE USA

At the Barrett Company, we believe "Made in America" still means something special— Quality, Dependability, Safety, Reliability— products that feature the most advanced technologies and the best value. When you buy American, you not only buy the best, you help our country curb import-export imbalances, grow employment, calm inflation, and strengthen our industrial infrastructure. All of our products are proudly Made in America.

APPROVED CONTRACTORS

Service with expertise is the hallmark of every Barrett warranted project. Barrett roofing & waterproofing warranted applications must be installed by Barrett-approved contractors. Each fully approved contractor is experienced, knowledgeable, and carefully selected at the time of approval.

WARRANTIES

The Barrett Company offers a variety of long-term warranties for labor & materials for up to 30 years. Terms vary depending on the product and application.

QUALITY CONTROL

Over \$50 million has been invested in the research, technology, & development of our product lines. Each polymer-modified bitumen production run is individually certified to be in conformance with specifications prior to shipping. Barrett's expert technical staff is available to work with designers & specifiers during project development & construction to assure proper design & installation. Many of our systems hold UL & FM, ICC, ASTM, & Miami Dade approvals/certifications.

THE ENVIRONMENT

The Barrett Company makes the environment a priority in the engineering, manufacturing, and recycled content of its roofing & waterproofing products. RamTough 250 bitumens are manufactured with recycled tires, and their reinforcement includes recycled plastics. Energy Star® Certified roof coatings are offered for most systems, which can contribute to LEED® credits. Greenroof-Roofscapes® offer many environmental contributions well beyond any other roof type.

No project is too small to be considered important. No detail is insignificant in the delivery of our product. No compromise of installation shall be considered acceptable without the concurrence of the building owner & the architect.

***Our service is our uniqueness.
Our reputation is proof.***

A stylized, dark brown illustration of a ram's head and upper body, facing forward. The ram has large, curved horns and a thick, textured beard. The illustration is set against a solid dark brown background.

RamTough 250

Hot Fluid Applied Rubberized Asphalt
Roofing & Waterproofing Membrane

RamTough 250



RamTough 250

Hot Fluid Applied Rubberized Asphalt Roofing & Waterproofing Membrane

The uncompromising, tough, flexible membrane, **RamTough 250** delivers design workability, durability and provides the owner with a single-source warranty system.

RamTough 250 is composed of SBS rubber polymers, specially refined unoxidized asphalt, mineral filler and recycled tire rubber. This 100% solids thermoplastic rubberized asphalt membrane forms a completely monolithic waterproofing system without seams and joints.



Using a double-jacketed, hot air, or oil bath melter, RamTough 250 is heated on the jobsite to a fluid state and spread onto the deck & walls. It is reinforced with spunbond polyester and neoprene flashing, creating a minimum 215 mil thick protective waterproof membrane.

The material's web-like molecular structure creates a microscopic elastic network of strong, rubberized strands. During the polymerization process, the rubber network absorbs the bitumen to produce a rubber-like waterproofing material with exceptional self-healing properties, excellent toughness, tenacity, fatigue resistance, and flexibility, especially at cold temperatures.



Easy to install

Completely monolithic membrane with no seams or joints

Superior elongation & flexibility

Installation between 0°F and 120°F

100% Solids— No solvents, urethanes, etc.

History of proven performance

APPLICATIONS

- New & Restoration Applications
- Plaza Decks
- PMR/IRMA®
- Greenroof-Roofscapes®
- Vertical Waterproofing
- Laggings & Sheet Piling
- Parking Decks
- Bridge Decks
- Split & Mud Slabs
- Tunnels
- Blindside Walls
- Foundation Walls
- Planters
- Water Treatment Facilities

- Ram 203 Protection Course
- RamTough 250 2nd Coat (125 mils)
- PolyFelt 125VP Reinforcement Fabric
- RamTough 250 1st Coat (90 mils)
- Ram Primer & Surface Conditioner
- Concrete Deck

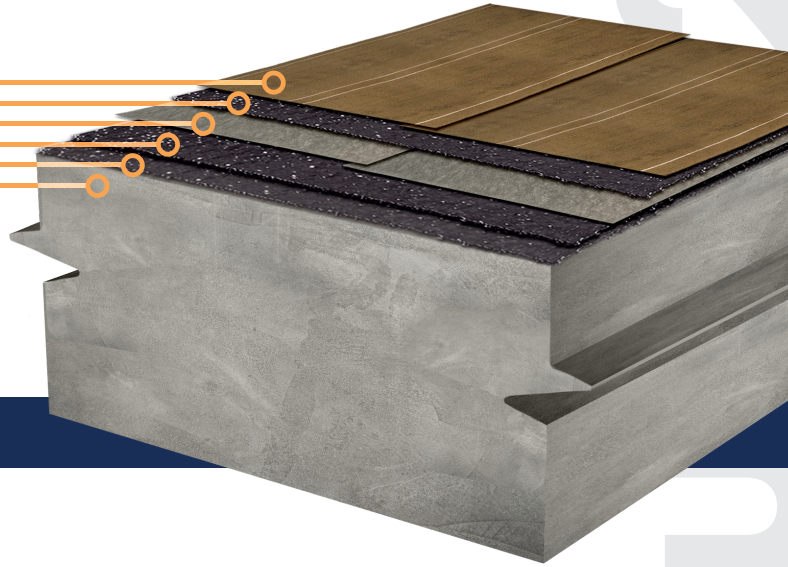

Non-Nailable Deck

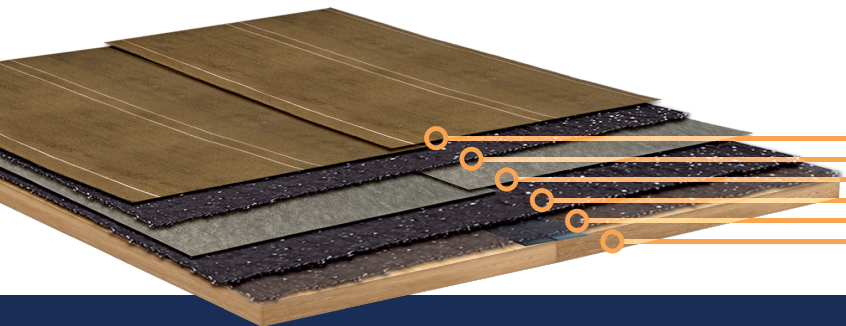

- Ram 203 Protection Course
- RamTough 250 2nd Coat (125 mils)
- PolyFelt 125VP Reinforcement Fabric
- RamTough 250 1st Coat (90 mils)
- Ram Primer & Surface Conditioner
- Wood Deck

Nailable Deck





Black Pearl®

Cold Fluid Applied Rubberized Asphalt
Roofing & Waterproofing Membrane

Black Pearl®



Black Pearl®

Cold Applied Rubberized Asphalt Roofing & Waterproofing Membrane

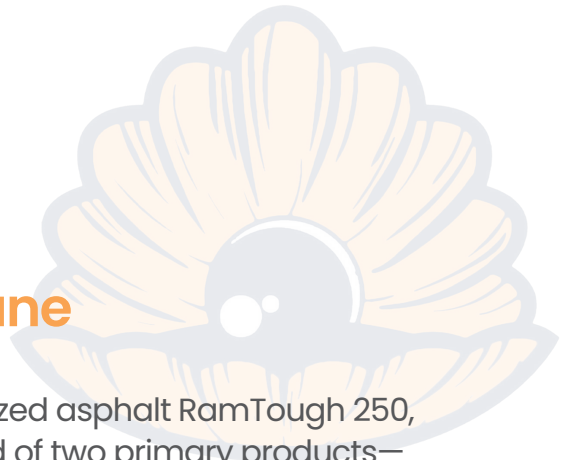

Designed as a cold-applied alternative to the hot rubberized asphalt RamTough 250, Barrett's **Black Pearl®** Waterproofing System is composed of two primary products—Black Pearl® Adhesive & Black Pearl® Sheet Membrane.

Black Pearl® Adhesive utilizes a core formula of select, unoxidized asphalt cement base, butyl rubber, styrene isoprene styrene (SIS), neoprene rubber, styrene-butadiene-styrene rubber (SBS), carbon black, fillers, plasticizers and curing agents. The Black Pearl® Primer Adhesive also contains an aliphatic solvent that is within current OSHA & EPA current regulations.

Black Pearl® Sheet Membrane is a 55 mil fiberglass-reinforced woven polyester fabric that has been coated on both sides with the same Black Pearl® rubberized formula as its adhesive counterpart. Both sides of the coated fabric are protected by a peelable polyethylene release liner, which allows for easy staging & walkability during application.

The compatibility between the two components is 100 percent, with the Black Pearl® Adhesive acting as a catalyst on the sheets and chemically fusing the system elements together (including flashings) into a thick, monolithic waterproof membrane.



Easy to install

Monolithic membrane with 100% chemical bond

All-Season Material; Can be installed anytime between 0°F and 120°F

Compatible with XPS, PVC, EPDM, Concrete, Modified Bitumen, & more

Can be applied to green concrete

APPLICATIONS

- New & Restoration Applications
- Plaza Decks
- PMR/IRMA®
- Greenroof-Roofscapes®
- Vertical Waterproofing
- Laggings & Sheet Piling
- Parking Decks
- Bridge Decks
- Split & Mud Slabs
- Tunnels
- Blindside Walls
- Foundation Walls
- Planters
- Water Treatment Facilities

- Ram 203 Protection Course
- Black Pearl® Adhesive (20 mils)
- Black Pearl® Sheet Membrane
- Black Pearl® Adhesive (20 mils)
- Black Pearl® Sheet Membrane
- Black Pearl® Adhesive (20 mils)
- Concrete Substrate

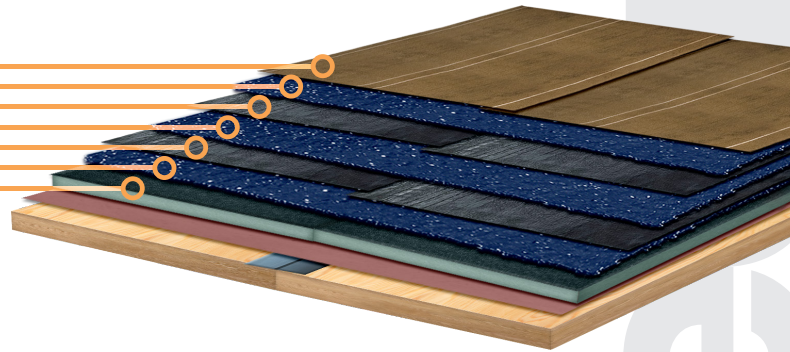

Non-Nailable Deck

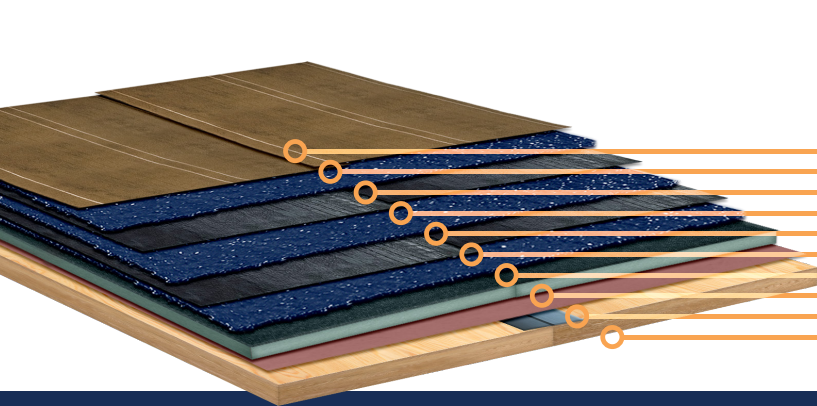

- Ram 203 Protection Course
- Black Pearl® Adhesive (20 mils)
- Black Pearl® Sheet Membrane
- Black Pearl® Adhesive (20 mils)
- Black Pearl® Sheet Membrane
- Black Pearl® Adhesive (20 mils)
- DensDeck Prime Roof Board (1/2")
- Red Rosin Paper
- Black Pearl® Butyl Tape
- Wood Deck

Nailable Deck

TOOLS



A large, stylized graphic of a ram's head with prominent, curved horns, rendered in a dark brown color against a lighter brown background. The ram is facing forward, and its features are defined by bold, dark lines.

RamTough KLB-100

Hot Applied SEBS Modified Asphalt
Elastomeric Built-Up Roofing System

RamTough KLB-100



RamTough KLB-100

Hot Applied SEBS Modified Asphalt Elastomeric Built-Up Roofing System

RamTough KLB-100 roof assemblies offer the elastomeric properties of single ply with the time proven redundancy and abuse resistance of Built-Up Roofing technology.

RamTough's elastomeric mopping bitumen combines Kraton® SEBS rubber polymer with a highly select grade of unoxidized asphalt creating a thermoplastic elastomeric mopping material. The rubberized material's weblike molecular structure creates a microscopic elastic network of strong rubberized strands.

During the polymerization process, the network absorbs the bitumen, producing a waterproofing material with excellent self-healing properties, toughness, tenacity, fatigue resistance, and cold temperature flexibility.

Commonly known as the "bullet-proof roof" a four-ply configuration is the toughest roof available and can literally stop a 22-caliber bullet.

Extraordinary toughness

Superior capabilities compared to ordinary, oxidized asphalt

Manufactured with select bitumen & Kraton® SEBS rubber polymer

"Bulletproof Roof;" 4-Ply assembly can literally stop a 22-cal bullet

Warranted up to 25 years

APPLICATIONS

- Built-Up Roofing
- Plaza Decks
- PMR/IRMA®
- Greenroof-Roofscapes®
- Vertical Waterproofing
- Parking Decks
- Bridge Decks
- Split Slab
- Tunnels
- Water Treatment Facilities

- **Gravel Surface**
- **RamTough KLB-100 Flood Coat** (25-30 lbs)
- **PolyFelt 265VP Polyester Reinforcement Fabric**
- **RamTough KLB-100 4th Coat** (25-30 lbs)
- **PolyFelt 265VP Polyester Reinforcement Fabric**
- **RamTough KLB-100 3rd Coat** (25-30 lbs)
- **PolyFelt 265VP Polyester Reinforcement Fabric**
- **RamTough KLB-100 2nd Coat** (25-30 lbs)
- **PolyFelt 265VP Polyester Reinforcement Fabric**
- **RamTough KLB-100 1st Coat** (25-30 lbs)
- **XPS Roof Insulation**
- **Concrete Substrate**

KLB-100 4P-I-GS

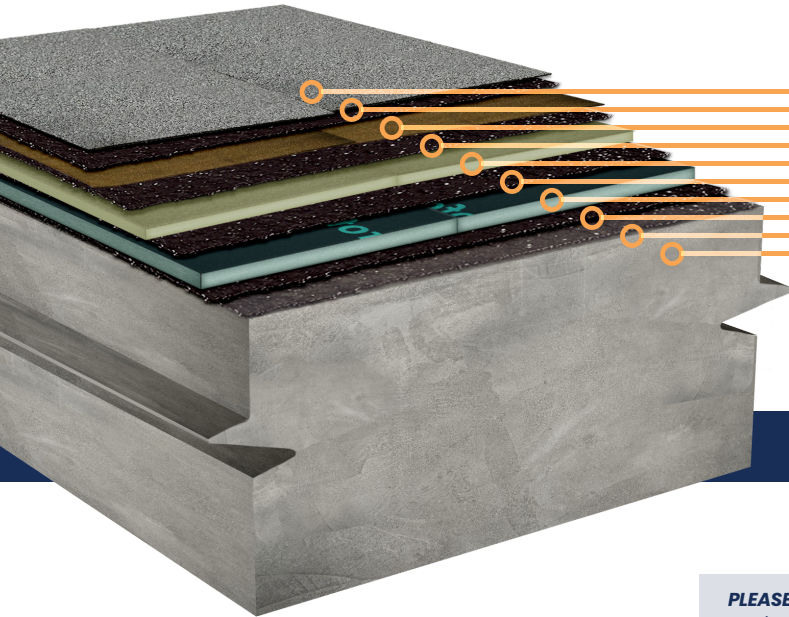
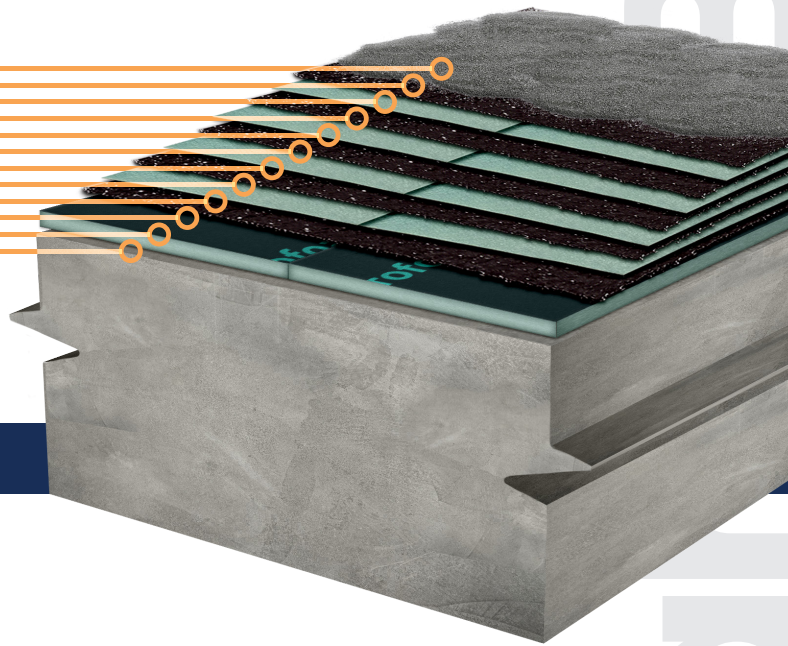

- **Ram 306 Granular Cap Sheet**
- **RamTough KLB-100 Flood Coat** (25-30 lbs)
- **Ram 200 SBS-Modified Protective Base**
- **RamTough KLB-100 3rd Coat** (25-30 lbs)
- **Roof Insulation (Top Layer)**
- **RamTough KLB-100 2nd Coat** (25-30 lbs)
- **Roof Insulation (Base Layer)**
- **RamTough KLB-100 1st Coat** (25-30 lbs)
- **Ram Primer & Surface Conditioner**
- **Concrete Substrate**

KLB-100 2P-I-CS

PLEASE NOTE: All coverage rates for RamTough KLB-100 are based around a **100 sq/ft application area.**

TOOLS





HyppoCoat GC

Single Component Elastomeric Modified Urethane
Horizontal & Vertical Waterproofing Membrane



GC
Coat

HyppoCoat GC

Single Component Modified Urethane Below-Grade Waterproofing Membrane Roofing & Waterproofing Membrane

HyppoCoat GC (Green Concrete) is a user-friendly, high solids, bitumen-modified, coal-tar free, single component liquid applied membrane for cured or green concrete. The system uses two coats of a modified urethane coating and protection board to create an elastomeric system designed to expand and contract with normal structural movements.

HyppoCoat GC is easy to use and can be applied immediately after green concrete forms have been removed, providing a very quick return-to-service window during application. It also acts as an aggressive barrier against harsh chemicals, abrasive wear, and heavy impact.

HyppoCoat GC is designed for use on foundations, backfilled walls, split slab applications, planters, and submerged conditions.

Single Component System

Quick return to service; Applied immediately after forms removal

100% Solids & Low VOCs

Easy, Labor-Saving Application

Economical Solution

APPLICATIONS

- Green Concrete
- Balconies
- Masonry
- Storage Areas
- Basements
- Tunnels
- Plaza Decks
- Foundation Walls
- Restrooms
- Parking Decks
- Planters
- Bridges

HyppoCoat GC Vertical

HyppoCoat GC Horizontal

Concrete Deck

Below-Grade

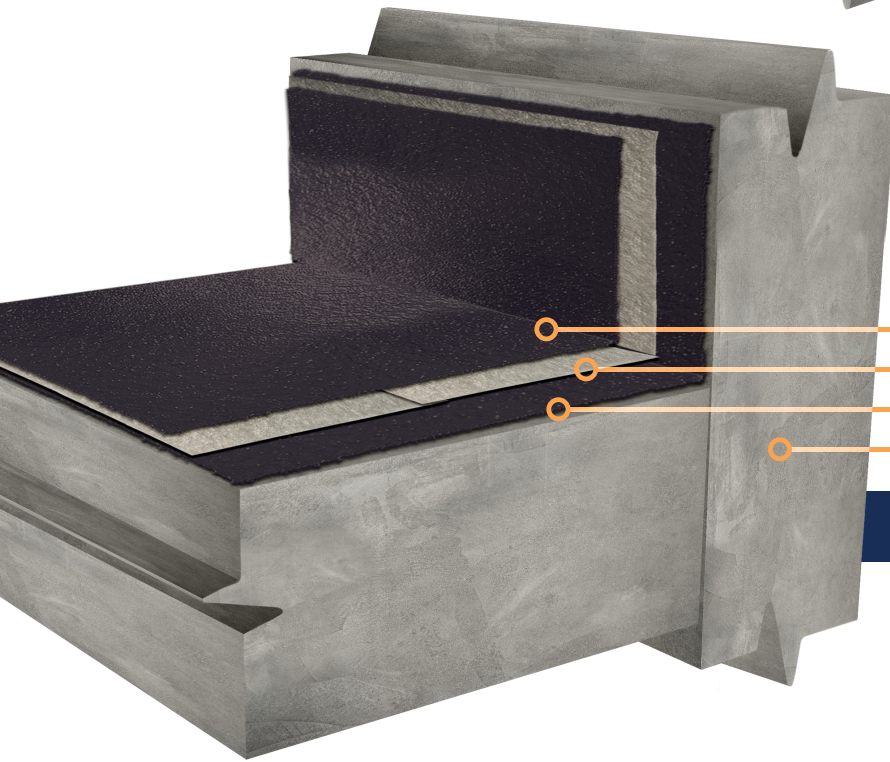
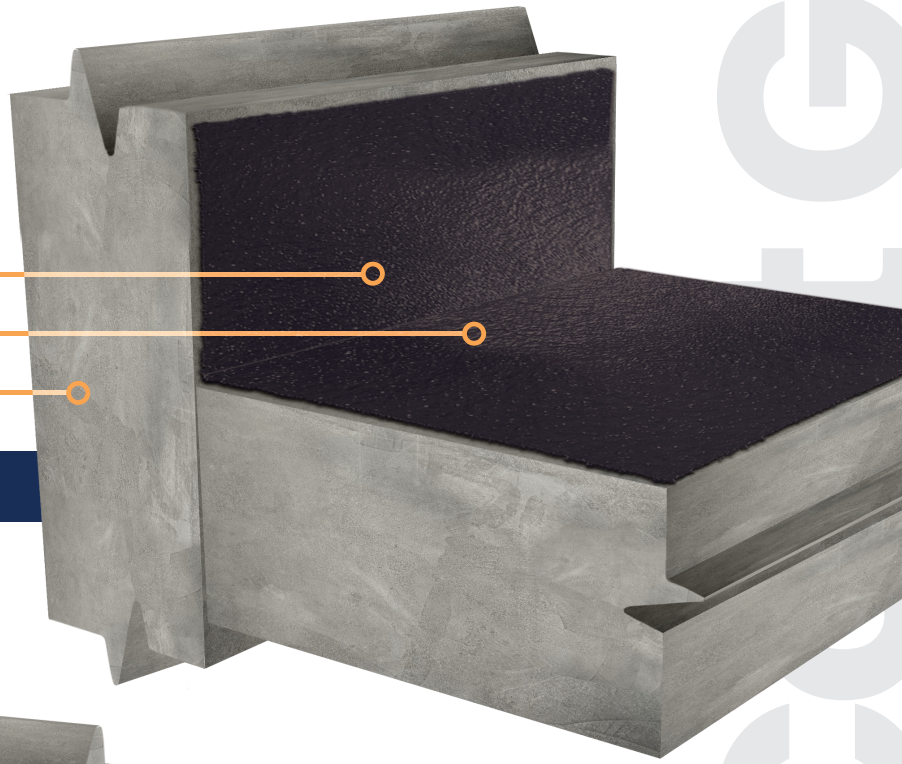

HyppoCoat GC (2nd Coat)

PolyFelt 125VP Reinforcement Fabric

HyppoCoat GC (1st Coat)

Concrete Deck

Below-Grade (Reinforced)

TOOLS



A stylized illustration of a ram's head and upper body, rendered in shades of brown and tan against a dark brown background. The ram has large, curved horns and a thick, textured beard. The illustration is positioned behind the main text.

RamProof GC

Single Component Fluid Applied Elastomeric
Rubberized Asphalt Waterproofing Membrane

Roam Pro



THAT'S A
SERVABLE
IDER
ALL DAY
EVER

RamProof GC

Single Component Modified Urethane Below-Grade Waterproofing Membrane Roofing & Waterproofing Membrane

RamProof GC (Green Concrete) is comprised of an industry changing asphaltic-rubber formulation that combines the elastic properties of modified rubber with the weatherproofing and waterproofing characteristics of emulsified asphalt. The resulting asphaltic-rubber membrane provides a complete, high-performance waterproofing membrane that is VOC-free, environmentally friendly, rapidly installed, and delivers a complete solution for the entire scope of waterproofing.

RamProof GC forms to a single set, fully adhered, monolithic, and seamless membrane that results in a high-performance membrane that resists hydrostatic pressure, bridges cracks and will move with created expansion and contraction of surfaces.

Single Component System

Expands & Contracts

+1000% Elongation & Self Healing

Quick return to service; Applied immediately after forms removal

Eco-Friendly, No VOCs

Easy, Labor-Saving Application

LEED-Certified

Economical Solution

APPLICATIONS

- Green Concrete
- Warehouses
- Masonry
- Storage Areas
- Basements
- Tunnels
- Plaza Decks
- Plaza Decks
- Foundation Walls
- Restrooms
- Parking Decks
- Planters
- Bridges

RamProof GC Vertical
 RamProof GC Horizontal
 Concrete Deck

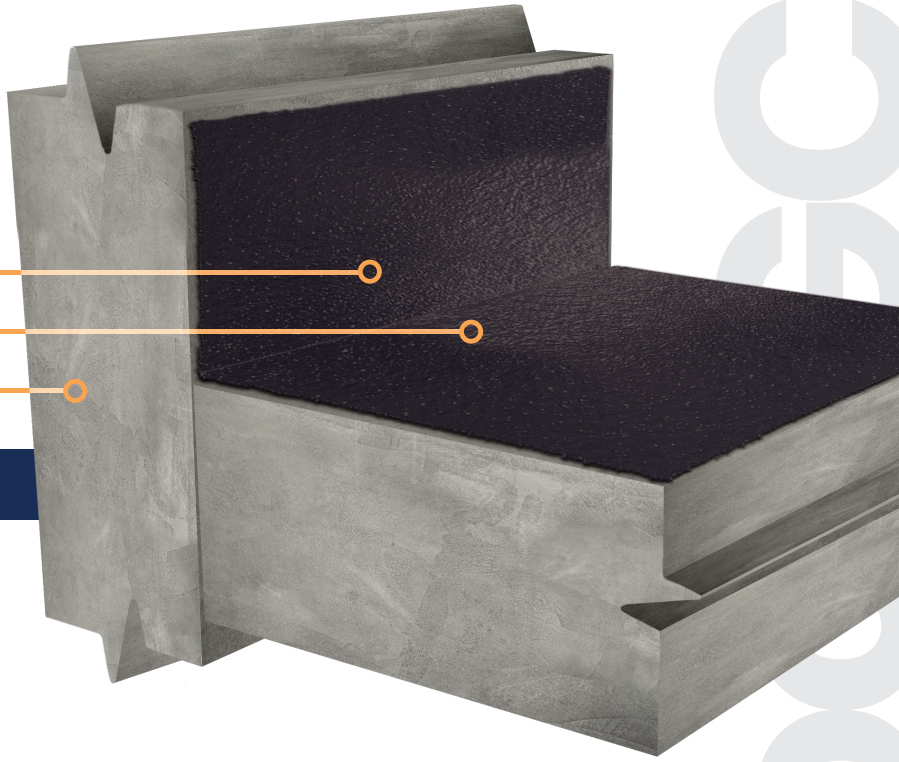

Below-Grade

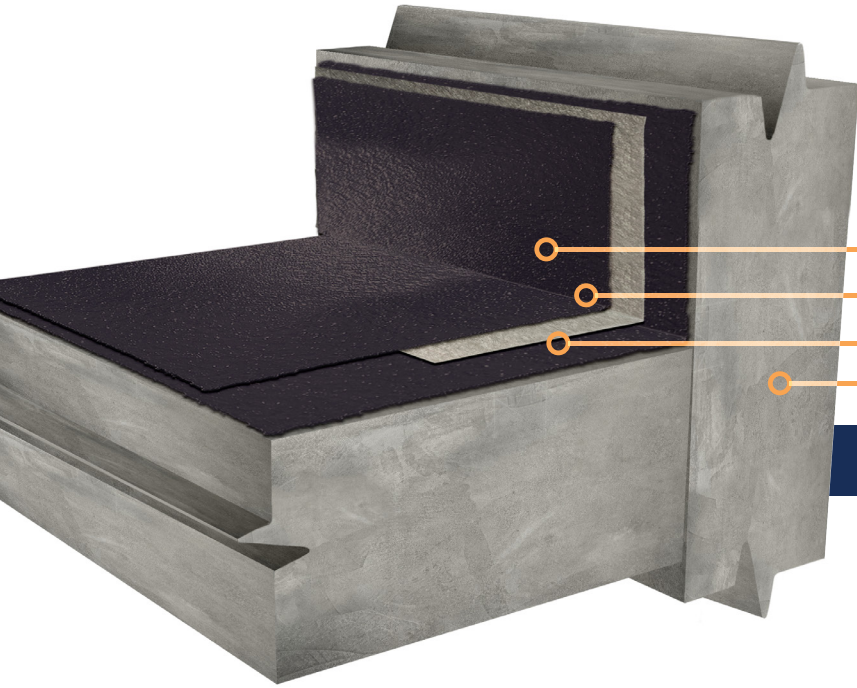

RamProof GC (2nd Coat)
 PolyFelt 125VP Reinforcement Fabric at transitions, penetrations, and drains
 RamProof GC (1st Coat)
 Concrete Deck

Below-Grade (Reinforced)

TOOLS



RamProof GC



HyppoCoat 100

**Hybrid Polyurea/Polyurethane
Balcony Deck Waterproofing System**

100+



HyppoCoat 100

Hybrid Polyurea/Polyurethane Balcony Deck Waterproofing System

HyppoCoat 100 is a two component, fast-setting, rapid-curing, solvent-free, high-performance & high-solids aliphatic polyurea/polyurethane waterproof coating that can be utilized suitably for heavy-duty wearing surface applications on prepared interior or exterior concrete, plywood, and metal surfaces.

Due to its fast gel time, HyppoCoat 100 is suitable for applications in temperatures as low as 20°F. It is also relatively insensitive to moisture and temperature, allowing for applications in various temperatures and humidity.



**Single Coat Application
at any thickness**

Fast-Curing, Seamless Application

Excellent Weatherability

Can be applied to Green Concrete

High Solids & Low VOCs

UV Stable Membrane

APPLICATIONS

- Balconies
- Parking Decks
- Plaza Decks
- Walkways, Patios, & Stairways
- Single Ply Roofs
- Metal Roofs
- Mechanical Rooms
- Pool Decks
- Roof Coatings
- Pond & Tank Liners
- Built-Up & Modified Roofs
- Polyurethane Foam
- Decorative Flooring
- Blocks & Masonry

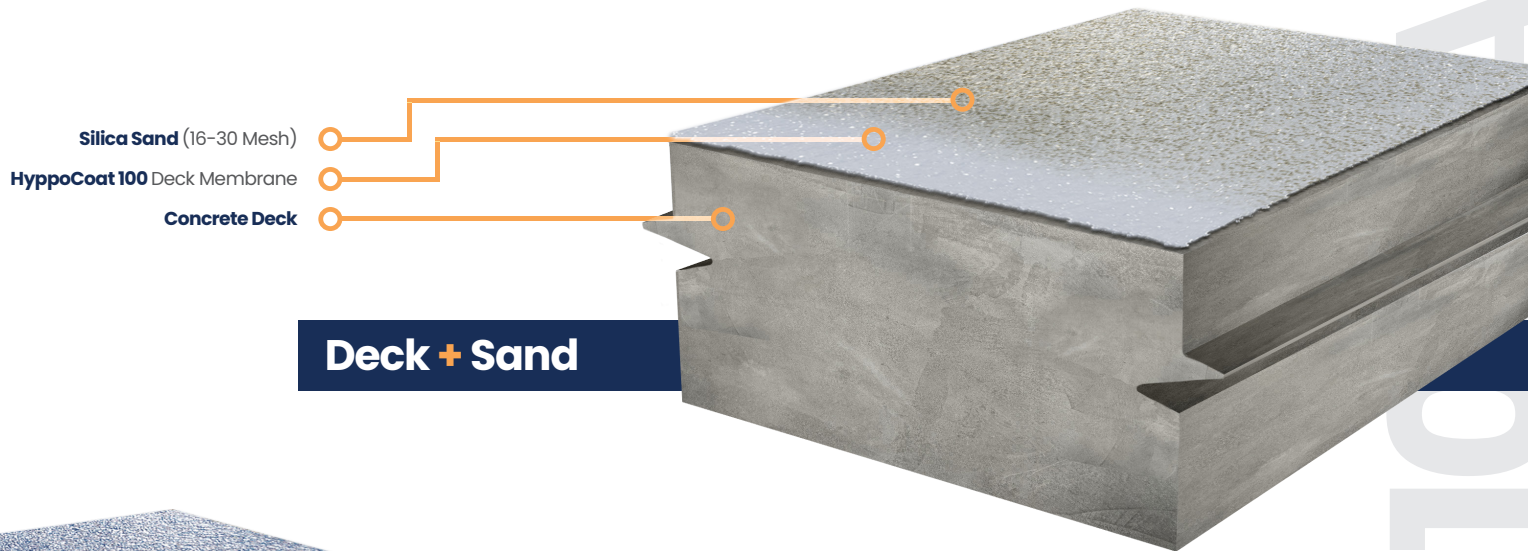

Deck + Sand

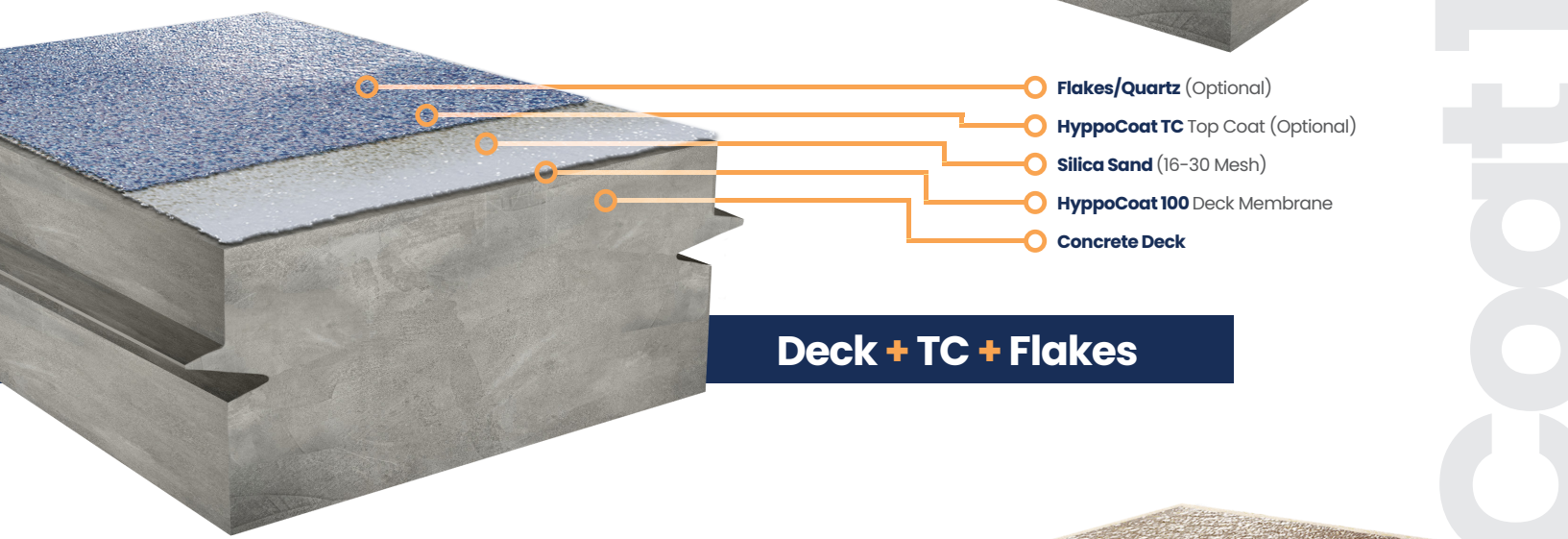

Deck + TC + Flakes

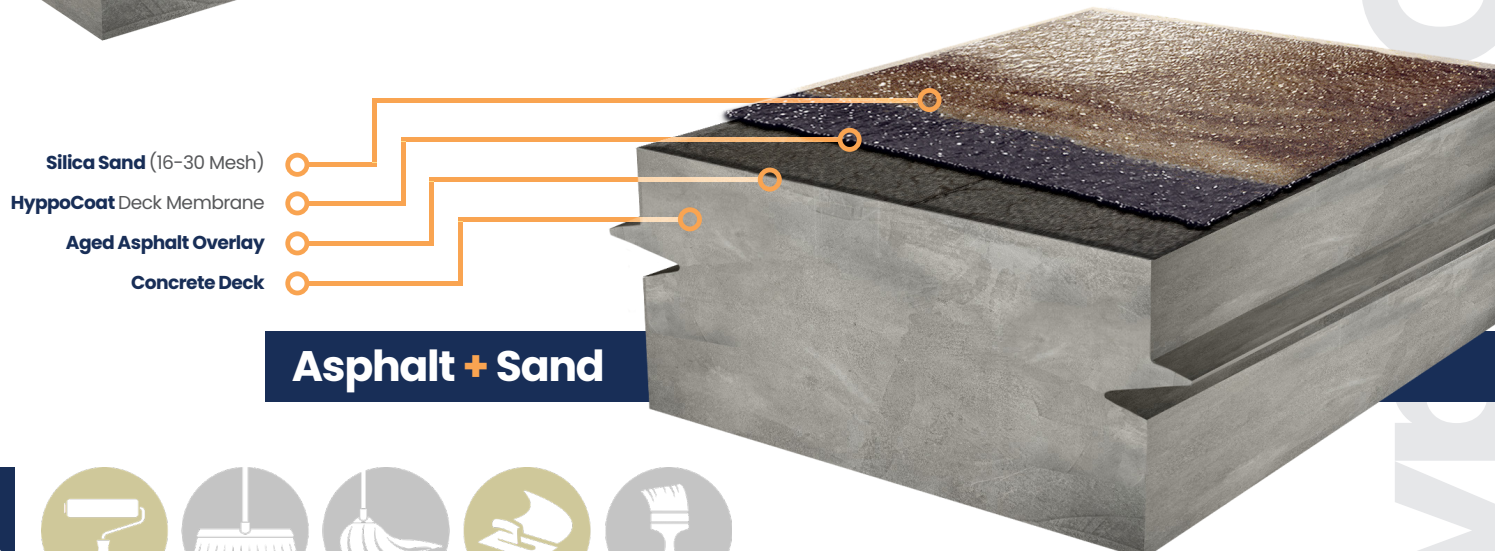

Asphalt + Sand

TOOLS





HyppoCoat 250

Water-Catalyzed Polyurethane
Trafficable Deck Waterproofing System

HyppoCoat 250



HyppoCoat 250

Water-Catalyzed Polyurethane Trafficable Deck Waterproofing System

HyppoCoat 250 is a liquid applied, high-solids, water-catalyzed polyurethane deck system that creates a seamless, joint-free, tack-free membrane for concrete, wood, and metal surfaces. HyppoCoat 250 is a Class A Fire Rated System by Miami-Dade County.

HyppoCoat 250 is composed of three primary products:

HyppoCoat PC is a two component, solvenated, epoxy-polyamine liquid-applied primer with unique penetrating characteristics, low viscosity, and excellent adhesion.

HyppoCoat BC is a non-gassing, solvent-free, single component, liquid applied, water-catalyzed elastomeric polyurethane waterproofing basecoat.

HyppoCoat TC is a two-component, very high solids, fast-setting, rapid curing aliphatic hybrid elastomeric topcoat that can be applied to properly prepared interior or exterior concrete, plywood and metal surfaces.

HyppoCoat 250 can be applied to protect surfaces against spalling, freeze/thaw damage, and chemicals commonly encountered on these surfaces. It is an elastomeric system designed to expand and contract with normal structural movements. It will not soften in heat, nor will it become brittle in the cold.

Durable, Waterproof Pedestrian & Vehicular Systems

Seamless Application

Non-Gassing

Miami Dade Approval

Solvent Free

High Tensile Strength

APPLICATIONS

- Plaza Decks
- Parking Decks
- Concrete & Plywood Decks
- Balconies & Breezeways
- Sloping Decks
- Pool Decks
- Concrete Bridges
- Under-Tile Waterproofing
- Pond & Tank Liners
- Mechanical Rooms
- Concrete Parking Garages
- Pedestrian Areas

- HyppoCoat TC Top Coat
- Silica Sand (16-30 Mesh)
- HyppoCoat BC Base Coat
- HyppoCoat PC Primer Coat
- Concrete Deck

Pedestrian

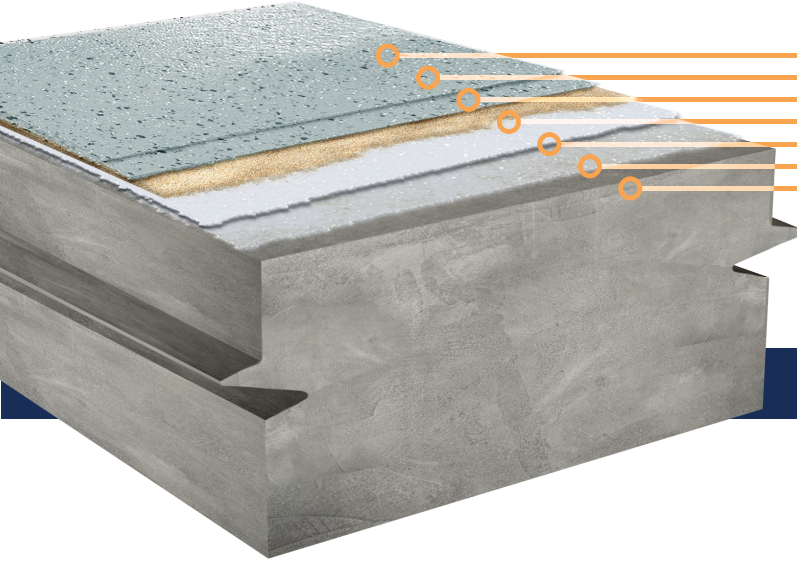
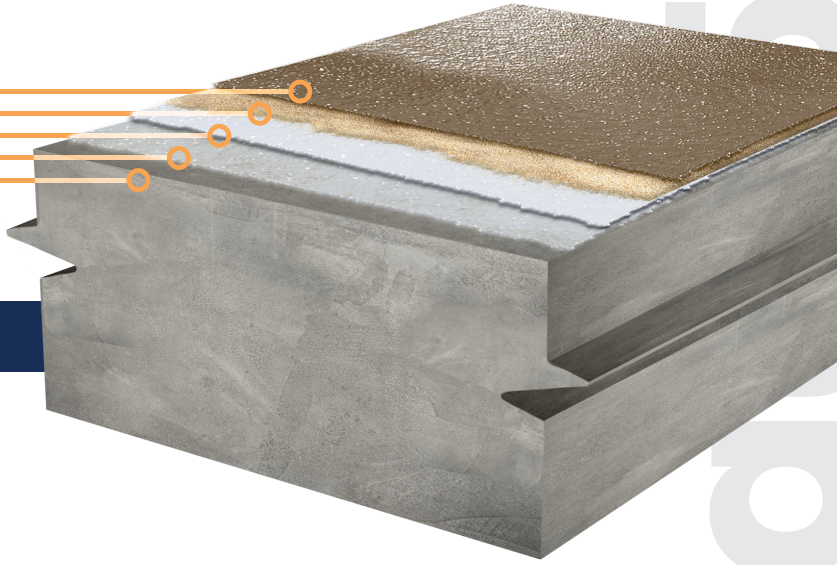

Vehicular

- Flakes/Quartz (Optional)
- HyppoCoat TC 2nd Coat (Optional)
- HyppoCoat TC Top Coat
- Silica Sand (16-30 Mesh)
- HyppoCoat BC Base Coat
- HyppoCoat PC Primer Coat
- Concrete Deck

TOOLS



A large, stylized graphic of a ram's head and upper body, rendered in dark grey and black with some red accents. The ram has large, curved horns and a thick, textured beard. The background is a solid dark grey.

Ram Cold Tar[®] Plus

Single Component Fluid Applied
Elastomeric Roof Restoration Coating



Ram Cold Tar® Plus

Ram Cold Tar® Plus

Single Component Fluid Applied Elastomeric Roof Restoration Coating

Ram Cold Tar® Plus is a unique thermoplastic SBS rubber coating compound that is used for the repair and restoration of existing asphalt, coal tar, and modified bitumen membrane systems.

Using the existing membrane as its base, Ram Cold Tar® Plus adheres over the surface to create a new, durable, monolithic, elastomeric membrane that is resistant to ponding water and other detrimental roof elements.

ROOF RESTORATION & REPAIR

Used as part of a total restoration procedure, a Ram Cold Tar® Plus system can be installed at a cost of up to 60% less than a typical re-roofing process. Many projects can be expensed the same year, avoiding long-term depreciation limits.

COLD PROCESS BUILT-UP ROOFING

Ram Cold Tar® Plus built-up roof assemblies offer the benefits of a cold applied liquid system with the superior durability typically associated with hot applied, multi-ply membranes. This system is recommended for poorly draining and low-slope roof decks when long-term performance and limited maintenance is desired.

For optimum performance in exposed roof applications, Ram Cold Tar® Plus should be coated with gravel, granules, or an Energy Star® approved reflective coating.

Economical; 40–60% less than cost of full Roof Replacement

Quick & Easy Application

2000% Elongation

Multiple Surfacing Options

Resists Ponding Water

Classified as a repair; Can be written off in the same year

APPLICATIONS

- New, seamless, elastomeric membrane for new or existing bituminous roofing membrane systems
- Restoration & repair of asphalt & coal tar gravel-surfaced built-up roof membranes
- Resurfacing of smooth & granulated asphalt built-up roofing systems & modified bitumen membranes
- Can be surfaced with gravel, granules, or an Energy-Star rated Ram Ultra-White® or Ultra-Silver® Reflective Surface Coatings

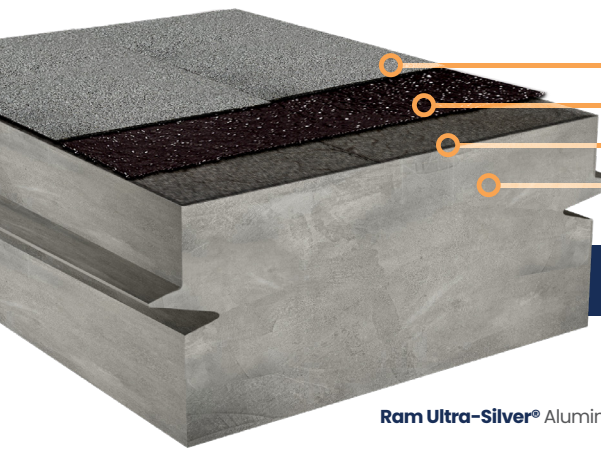

- Ram 306 Granular Cap Sheet
- Ram Cold Tar® Plus Rubberized Membrane
- Existing Roof Membrane
- Concrete Deck

RCT + Cap Sheet

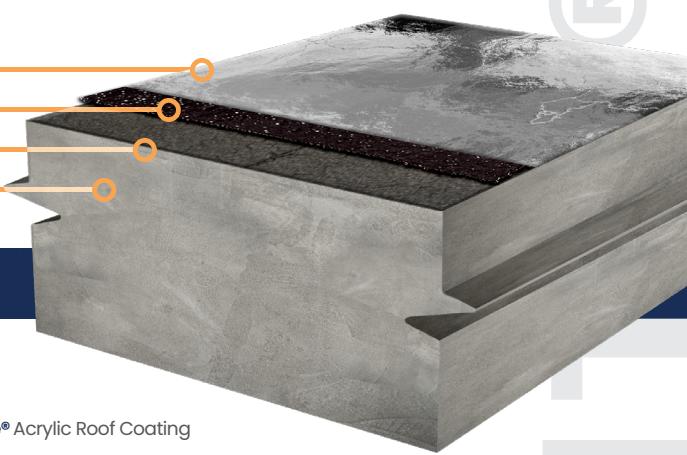

- Ram Ultra-Silver® Aluminum Roof Coating
- Ram Cold Tar® Plus Rubberized Membrane
- Existing Roof Membrane
- Concrete Deck

RCT + Aluminum Coat

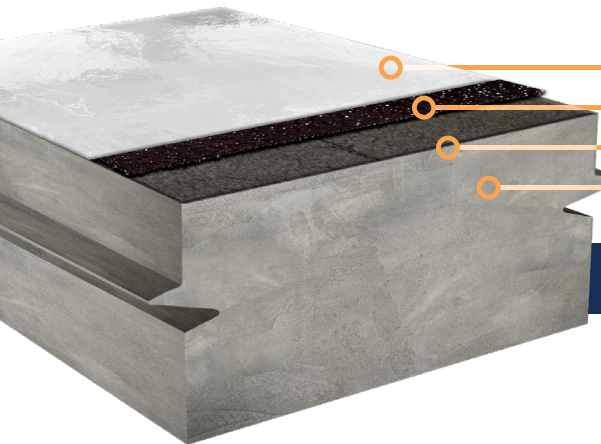

- Ram Ultra-White® Acrylic Roof Coating
- Ram Cold Tar® Plus Rubberized Membrane
- Existing Roof Membrane
- Concrete Deck

RCT + White Coat

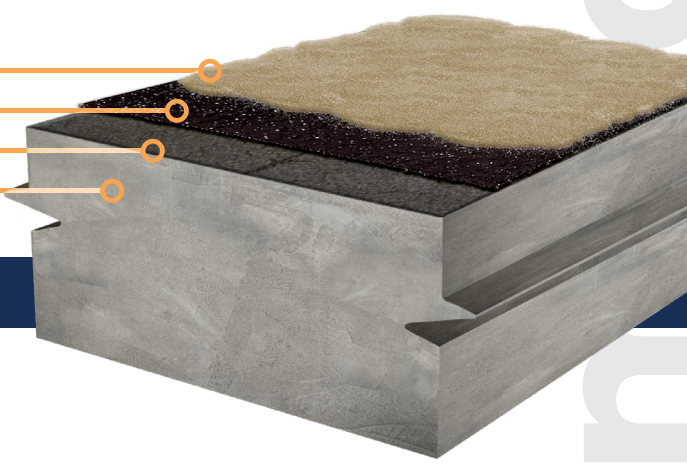

- Gravel/Ballast
- Ram Cold Tar® Plus Rubberized Membrane
- Existing Roof Membrane
- Concrete Deck

RCT + Gravel

TOOLS

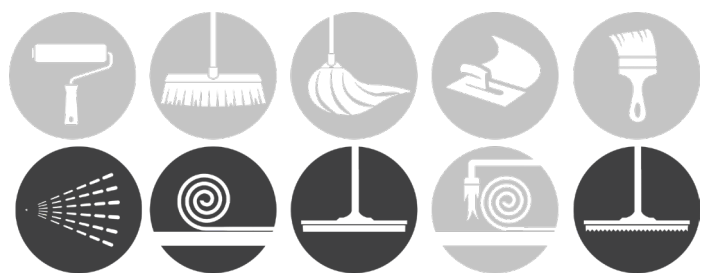

Ram QuikFlash® PMMA

Cold Fluid Applied Polymethyl Methacrylate
Roofing Membrane & Flashing System

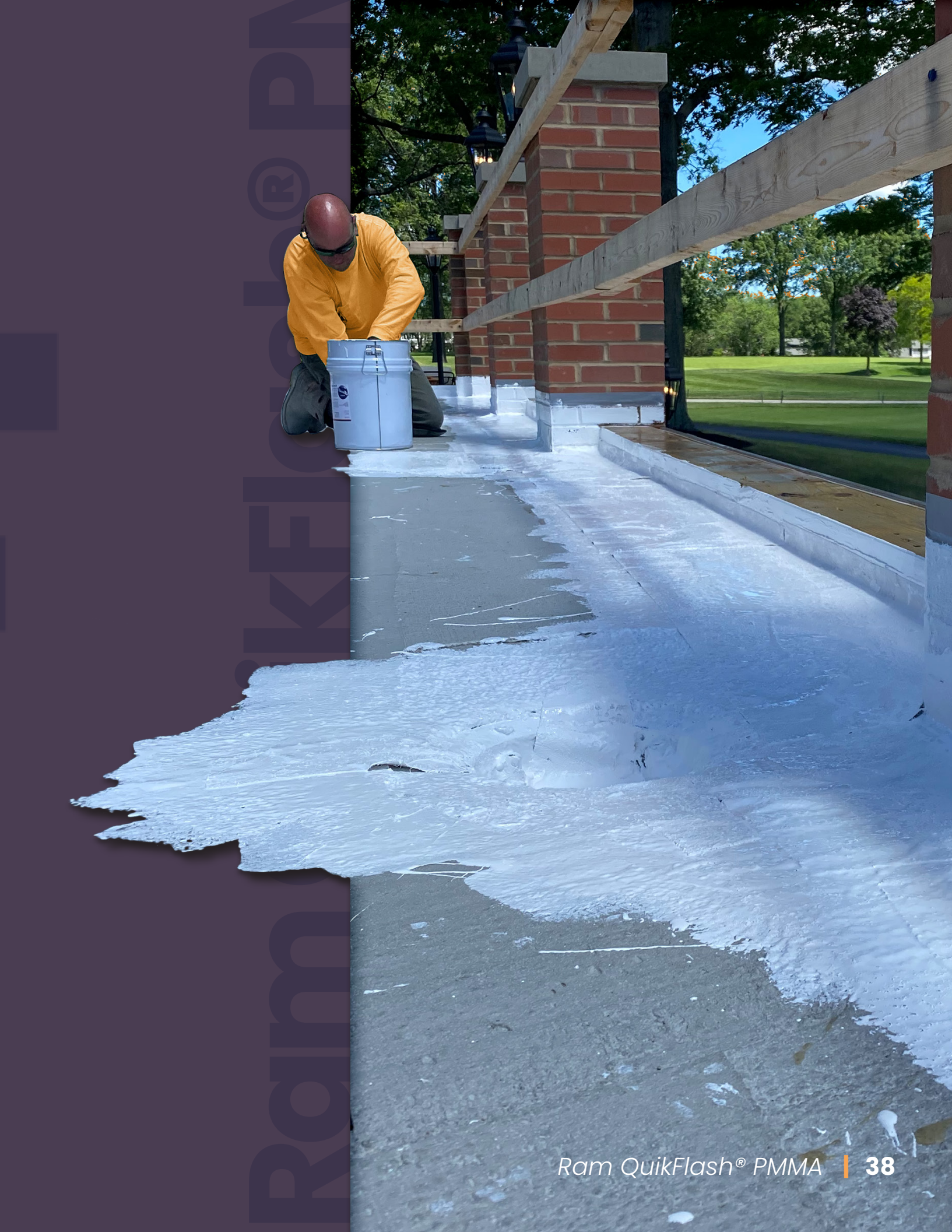

Ram QuikFlash® PMMA

Cold Fluid Applied Polymethyl Methacrylate Roofing Membrane & Flashing System

The Ram QuikFlash® PMMA roofing system is a fully reinforced, cold liquid-applied membrane system. It is based primarily upon Polymethylmethacrylate (PMMA) technology, incorporating a liquid component and a powdered catalyst, with each component curing in approximately one hour. A decorative PMMA finish can be applied as either a smooth color coating or a textured aggregate surfacing.

The Ram QuikFlash® PMMA same-day application is intended for use in roofing applications where quick-curing speed is of paramount importance. The system is exceptionally durable, reliable, long lasting, and has a combination of physical properties that makes it ideal for an exceptionally wide range of applications.

Ram QuikFlash® PMMA bonds tenaciously to all common construction materials including concrete, CMU block, brick, wood, stainless steel, copper, galvanized steel, aluminum, cast iron, glass, cement board, treated gypsum board, and rigid PVC.

COMPONENTS

- Ram QuikFlash® PMMA Primer
- Ram QuikFlash® PMMA Catalyst
- Ram QuikFlash® PMMA Membrane
- Ram QuikFlash® PMMA Fleece
- Ram QuikFlash® PMMA Finish

Durable, Reliable, and Lasting Protection

Fast Curing; Each Component Cures Within One Hour

High UV Protection & Elasticity

Optional Decorative Surfaces; Smooth or Textured Color Coatings

APPLICATIONS

- Roof Coating
- Roof Decks
- IRMA® Roofing
- Insulated Roofing
- Roof Recovery
- Green Roofs
- Blue Roofs
- Wall/Curb Flashing
- Pedestrian Areas
- Balconies
- Pool Decks
- Metal Roofs

- Ram QuikFlash® PMMA Membrane
- Ram QuikFlash® PMMA Fleece
- Ram QuikFlash® PMMA Membrane
- Ram QuikFlash® PMMA Primer
- Concrete Deck

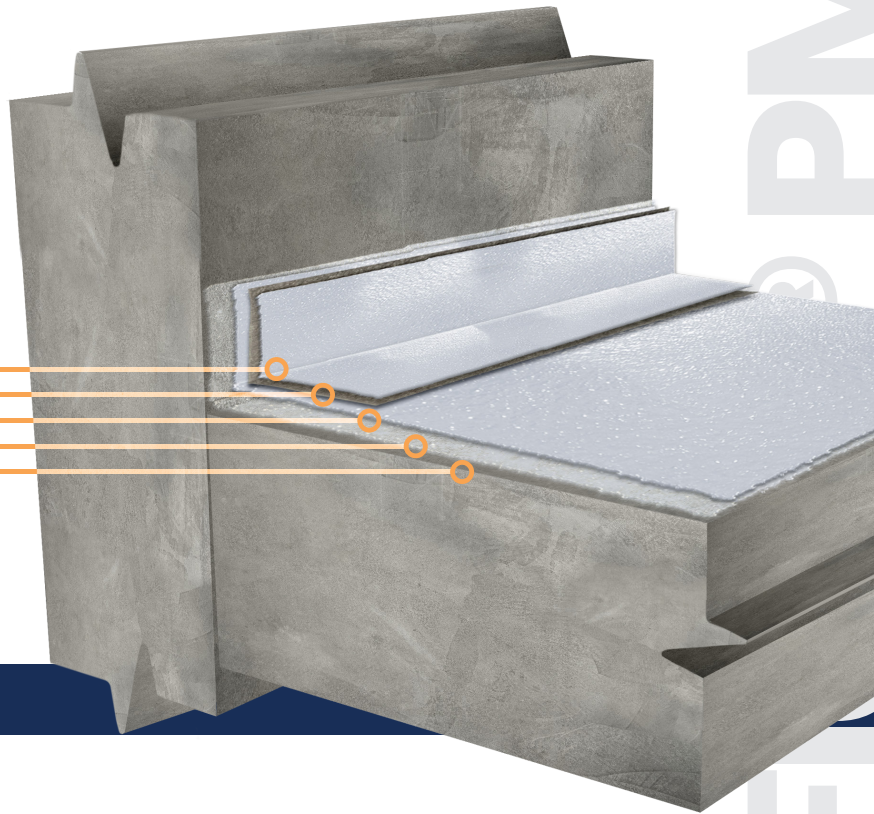

Typical Roof Flashing

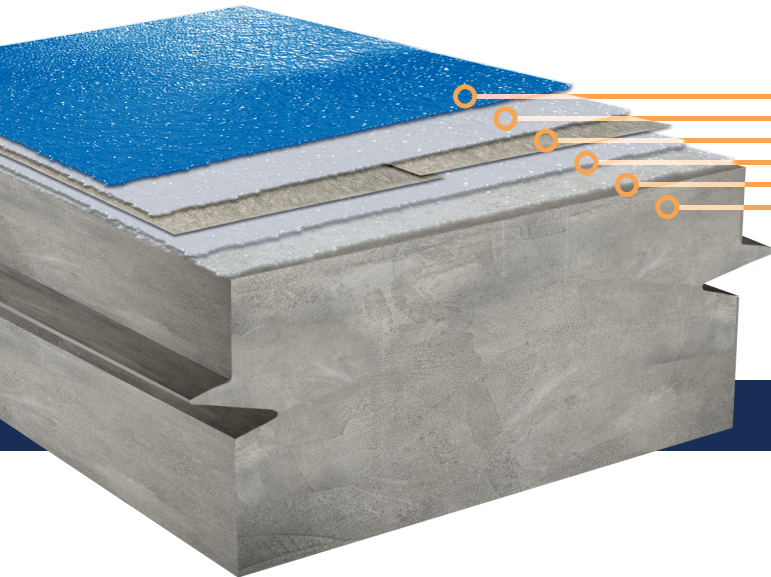

- Ram QuikFlash® PMMA Finish (Traffic Blue)
- Ram QuikFlash® PMMA Membrane
- Ram QuikFlash® PMMA Fleece
- Ram QuikFlash® PMMA Membrane
- Ram QuikFlash® PMMA Primer
- Concrete Deck

Trafficable Deck

TOOLS





Ram QuikFlash® PMMA



Ram QuikFlash® PMMA Membrane

Two-Component Liquid Applied PMMA Membrane

Ram QuikFlash® PMMA Membrane is a two-part quick-curing, UV-stable Polymethyl Methacrylate (PMMA) membrane. Due to its UV-stability, Ram QuikFlash® PMMA System is designed to be used both as an exposed roof coating, as well as a waterproof/roofing flashing material prior to installation of RamTough 250 and/or Black Pearl® systems.



Ram QuikFlash® PMMA Fleece

Non-Woven Needle-Punched Polyester Reinforcement Fabric

RamFlash PMMA Fleece is a non-woven, needle-punched polyester fabric to reinforcement the RamFlash PMMA Membrane cold liquid-applied reinforced PMMA waterproofing membrane systems. Ram QuikFlash® PMMA Fleece provides reinforcement for the Ram QuikFlash® PMMA Membrane to improve strength, tear, and puncture resistance while the membrane remains uniform.



Ram QuikFlash® PMMA Catalyst

Fiberglass Reinforced SBS Modified Asphalt Protective Base Sheet

Ram QuikFlash® PMMA Catalyst is an initiator agent based on 50% dibenzoyl peroxide to induce the cure of Ram QuikFlash® PMMA Membrane and Ram QuikFlash® PMMA Primer. Ram QuikFlash® PMMA Catalyst (300g bag) to be used with Ram QuikFlash® PMMA Membrane and RamFlash PMMA Catalyst (100g bag) to be used with Ram QuikFlash® PMMA Primer.



Ram QuikFlash® PMMA Primer

Two-Part Polymethyl Methacrylate Primer

Ram QuikFlash® PMMA Primer is a two-part quick-curing primer for porous and non-porous substrates to prepare for the application of RamFlash PMMA Membrane. Ram QuikFlash® PMMA Primer is designed to prepare substrates for the Ram QuikFlash® PMMA Membrane system to be used in conjunction with RamTough 250 and/or Black Pearl® Membranes.



Greenroof Roofscaapes®

Complete Waterproofing Systems
for Green Roof + Landscape Assemblies



Greenroof-Roofscapes®

Complete Waterproofing System for Green Roof + Landscape Assemblies

The roof is often a forgotten element on most buildings. When designed and built as a multi-functional element, however, a roof space can be made cost effective, provide significant environmental contributions, and create aesthetically pleasing, versatile, and usable outdoor spaces.

Barrett's **Greenroof -Roofscapes®** are sustainable roofing & landscaping systems that offer the owner and society many environmental benefits, low lifecycle costs, and government incentives.

Greenroof-Roofscape® systems are designed around inter-dependent components which function as a natural vegetation habitat, encouraging biodiversity. These eco-centric assemblies can turn any space into a park-like garden setting with a keen sensitivity to environmental enhancement, restoring nature's footprint over the building while creating a public or private open space that offers the potential of serenity, balance, harmony, and true sustainability.

WATERPROOFING MEMBRANE

The waterproofing membrane is the most critical element of successful green roofs. It must assure a long-term, trouble-free, watertight base for the superimposed green roof assembly. Barrett's **RamTough 250**, **Black Pearl®**, and **RamTough KLB-100** Elastomeric BUR systems all offer time-proven performance in this type of demanding application.

Greatly Reduces or Eliminates Stormwater Runoff

Low Life Cycle Cost

Increases Energy Efficiency

Reduces Urban Heat Island Effect

Converts Carbon Dioxide to Oxygen, Improving Urban Air Quality

APPLICATIONS

- Extensive
- Semi-Intensive
- Intensive
- Wood Pavers
- Stone Pavers
- PMR/IRMA®
- Planter Box



Pre-Grown Trays



Extensive



Intensive

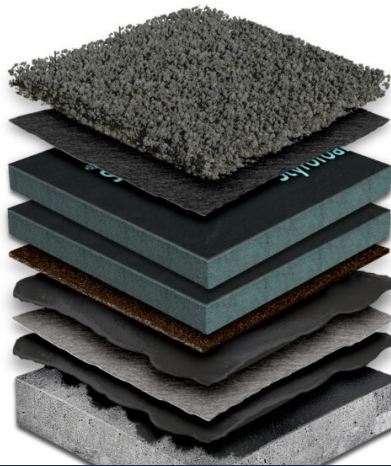

PMR | Ballast

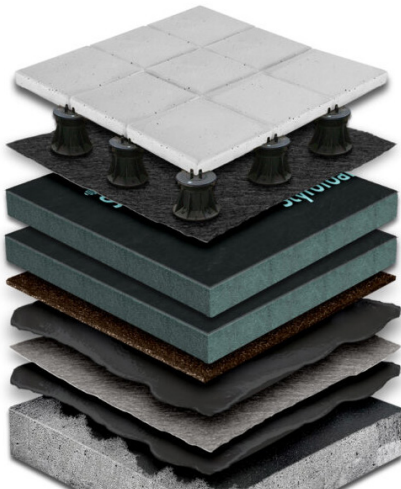

Stone Pavers

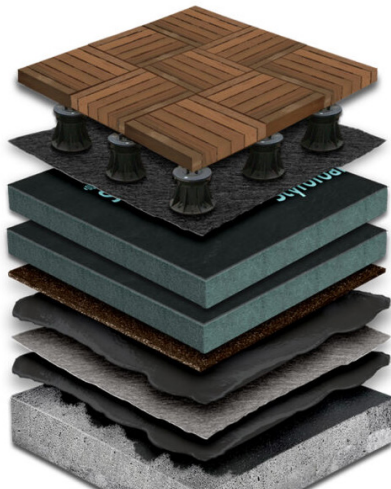

Wood Pavers

Greenroof-Rootscapes®

Below

Below-Grade & Foundation Waterproofing Systems

Every building owner has the right to expect a leak-free, watertight system that will stay that way beyond the warranty period.

With nearly a century of experience providing top quality roofing & waterproofing systems for leading architects, engineers, and builders of modern structures, we can say with confidence that no finer materials of this character are obtainable than those bearing the Barrett label.

The Barrett Company offers a range of time-proven systems for below-grade waterproofing, including positive, negative, and blind-side applications. Recognized as a national leader in evolving bitumen modification technology and the design of high-performance waterproofing, built-up roofing systems, and vegetated roofs, these warranted Barrett systems can guarantee watertight protection from the ground up.



Grade

1

VERTICAL WATERPROOFING

2

HORIZONTAL WATERPROOFING

3

BASE FLASHING

2

RamShield® 60

Self-Adhering Below-Grade Sheet Waterproofing & Flashing Membrane

VERTICAL WATERPROOFING

- RamShield Adhesive Primer Adhesive
- RamShield 60 Self-Adhering Membrane
- RamDrain DD Dimpled Drainage Mat

BASE FLASHING

- KeeneSeal 100 Elastomeric Sealant
- RamShield Adhesive Primer Adhesive
- RamShield 60 Self-Adhering Flashing

WARRANTY

5-10 Years



RamProof GC

Single Component Fluid Applied Elastomeric Rubberized Asphalt Waterproofing Membrane

VERTICAL WATERPROOFING

- RamProof GC Elastomeric Membrane
- RamDrain DD Dimpled Drainage Mat

BASE FLASHING

- RamProof GC Elastomeric Membrane
- RamFlash 327 HDR Uncured Neoprene

WARRANTY

10-20 Years



Black Pearl®

Cold Fluid Applied Rubberized Asphalt Below-Grade Waterproofing System

VERTICAL WATERPROOFING

- Black Pearl® Primer Adhesive Cold Asphalt
- Black Pearl® Sheet Membrane Asphalt Sheet
- RamDrain DD Dimpled Drainage Mat

HORIZONTAL WATERPROOFING

- Ram 203 Protection Course
- Black Pearl® Primer Adhesive Cold Asphalt
- Black Pearl® Sheet Membrane Asphalt Sheet
- Black Pearl® Primer Adhesive Cold Asphalt
- Black Pearl® Sheet Membrane Asphalt Sheet
- Black Pearl® Primer Adhesive Cold Asphalt

BASE FLASHING

- Black Pearl® Primer Adhesive Cold Asphalt
- Black Pearl® Sheet Membrane Asphalt Flashing

WARRANTY

Up to 20 Years



RamTough 250

Hot Fluid Applied Rubberized Asphalt Below-Grade Waterproofing System

VERTICAL WATERPROOFING

- Ram Primer & Surface Conditioner
- RamTough 250 Hot Rubberized Asphalt
- RamDrain DD Dimpled Drainage Mat

HORIZONTAL WATERPROOFING

- Ram 203 Protection Course
- RamTough 250 Hot Rubberized Asphalt
- PolyFelt 125VP Reinforcement Fabric
- RamTough 250 Hot Rubberized Asphalt
- Ram Primer & Surface Conditioner

BASE FLASHING

- Ram Primer & Surface Conditioner
- RamTough 250 Hot Rubberized Asphalt
- RamFlash 327 HDR Uncured Neoprene

WARRANTY

Up to 20 Years



Liquid Membranes



RamTough 250

Hot Rubberized Asphalt Roofing & Waterproofing Membrane

A thermoplastic material, RamTough 250 Bitumen is a 100% solid polymer modified rubberized bitumen which forms a completely monolithic, waterproof barrier without seams or joints. Ram Tough 250 is designed to be installed in new and restoration applications such as plaza deck waterproofing systems, protected membrane roofs (IRMA®)*, GreenRoof Roofscapes®, Vertical waterproofing applications, parking decks, bridges, water treatment plants, and between slab waterproofing membrane systems.



Black Pearl® Adhesive

Cold Rubberized Asphalt Roofing & Waterproofing Membrane

Black Pearl® Adhesive utilizes a core formula of select, unoxidized asphalt cement base, butyl rubber, SIS, SBS, and neoprene rubber, carbon black, fillers, plasticizers and curing agents. Black Pearl® Adhesive also contains an aliphatic solvent that is within acceptable OSHA& EPA current regulations. Designed as a cold-applied alternative to the hot rubberized asphalt RamTough 250, the Black Pearl® Adhesive acts as a catalyst on the Black Pearl® Sheet Membrane, chemically fusing the system elements together into a thick, fully reinforced, monolithic waterproof membrane.



Ram Cold Tar® Plus

SBS Modified Asphaltic Roof Restoration & Repair Coating

Ram Cold Tar® Plus roofing-grade ply adhesive & waterproofing coating is a coal tar pitch fortified, thermoplastic SEBS polymerized surfacing compound that is specially formulated to adhere to asphalt, modified bitumen, gravel surfaced, and coal tar roofing systems. Using the existing bituminous roof mat as a substrate, Ram Cold Tar® Plus fuses a new, high-strength, fluid-applied rubbery membrane to the mass of the old roof mat, creating a new, double thick, elastomeric waterproof membrane.



HyppoCoat GC

Single Component Elastomeric Waterproofing Membrane

HyppoCoat GC (Green Concrete) is a user-friendly, high solids, single component, liquid applied membrane for cured or green concrete. The system uses two coats of a modified urethane coating and protection board to create an elastomeric system designed to expand and contract with normal structural movements. HyppoCoat GC is easy to use and can be applied immediately after green concrete forms have been removed, providing a quick return-to-service window during application. It also acts as an aggressive barrier against harsh chemicals, abrasive wear, and heavy impact.



RamProof GC

Single Component Fluid Applied Elastomeric Rubberized Asphalt Waterproofing Membrane

RamTough KLB-100 roof assemblies offer the elastomeric properties of single ply with the time proven redundancy & abuse resistance of Built-Up Roofing technology. RamTough's elastomeric mopping bitumen combines Kraton® SEBS rubber polymer with a select grade of unoxidized asphalt, creating a thermoplastic elastomeric mopping material with excellent self-healing properties, toughness, fatigue resistance, and cold temperature flexibility. Commonly known as the "bullet-proof roof," a four-ply system is the toughest roof available and can literally stop a 22-caliber speeding bullet.



RamTough KLB-100

Hot Applied SEBS Modified Asphalt Elastomeric BUR System

RamTough KLB-100 roof assemblies offer the elastomeric properties of single ply with the time proven redundancy & abuse resistance of Built-Up Roofing technology. RamTough's elastomeric mopping bitumen combines Kraton® SEBS rubber polymer with a select grade of unoxidized asphalt, creating a thermoplastic elastomeric mopping material with excellent self-healing properties, toughness, fatigue resistance, and cold temperature flexibility. Commonly known as the "bullet-proof roof," a four-ply system is the toughest roof available and can literally stop a 22-caliber speeding bullet.



Hypocoat 100

Hybrid Polyurea/Polyurethane Trafficable Deck Coating

Hypocoat 100 is a two component, fast-setting, rapid-curing, solvent-free, high-performance & high-solids aliphatic polyurea/polyurethane waterproof coating that can be utilized suitably for heavy-duty wearing surface applications on prepared interior or exterior concrete, plywood, and metal surfaces. Due to its fast gel time, Hypocoat 100 is suitable for applications in temperatures as low as 20°F. It is also relatively insensitive to moisture, allowing for applications in various temperatures and humidity.



Hypocoat BC

Water-Catalyzed Polyurethane Elastomeric Trafficable Base Coat

Hypocoat BC is a non-gassing, solvent-free, single component, liquid applied, water-catalyzed polyurethane elastomeric waterproofing basecoat. This unique product allows the base membrane to be applied in one application up to 3" (7.6 cm) deep down to a feather edge and cures simultaneously throughout the coating in approximately 4 hours at 75°F (24°C) and 50% relative humidity. The basecoat may be used for very rough or highly textured surfaces and where sloping or pond filling is desired.



Fabrics & Sheets



Black Pearl® Sheet Membrane

Asphalt-Coated Polyester Reinforced Peelable Sheet Membrane

Black Pearl® Sheet Membrane is a 55 mil fiberglass-reinforced woven polyester fabric that has been coated with the same Black Pearl® rubberized formula as its adhesive counterpart. On either side of the fabric is a peelable polyethylene release liner, which allows for easy staging for any application. The compatibility between the two components is 100 percent, with the Black Pearl® Primer Adhesive acting as a catalyst on the sheets and chemically fusing the system elements together (including flashings) into a thick, fully reinforced, monolithic waterproof membrane.



Ram 200

Polyester Reinforced SBS Modified Asphalt Sanded Base Sheet

Ram 200 is a multi-purpose polyester reinforced, SBS modified bitumen membrane with sanded surfaces. The polymer modification provides exceptional elongation, elastic and cold temperature flexibility properties. The high strength polyester reinforcement gives the composite membrane excellent tensile strength, toughness, puncture and tear resistance that exceeds typical rooftop exposures. Ram 200 can be installed in hot asphalt bitumen or approved cold applied adhesives and mastics.



Ram 201

Fiberglass Reinforced SBS Modified Asphalt Sanded Base Sheet

Ram 201 is a fiberglass-reinforced, polymer-modified asphalt sheet with sanded surfaces. The polymer modification provides exceptional elongation, elastic and cold temperature flexibility properties. The high strength polyester reinforcement gives the composite membrane excellent tensile strength, toughness, puncture and tear resistance that exceeds typical rooftop exposures. Ram 201 can be installed in hot asphalt bitumen or approved cold applied adhesives and mastics.



Ram 203

Fiberglass Reinforced SBS Modified Asphalt Sanded Protection Course

Ram 203 Membrane Protection Course is a multi-purpose SBS polymer-modified, fiberglass reinforced asphalt membrane with sanded surfaces, top and bottom. The polymer modification enhances this product's elongation, elasticity, and flexibility. The fiberglass reinforcement gives the composite membrane the tensile strength and toughness necessary to accommodate moderate exposures. This medium-duty membrane is utilized as a protection course in hot or cold applied rubberized asphalt waterproofing applications like Barrett's RamTough 250 & Black Pearl®.



Ram 306

Polyester Reinforced SBS Modified Asphalt Granular Cap Sheet

Ram 306 is a hot asphalt applied, mineral surfaced modified bitumen waterproofing membrane that is strong, puncture resistant and has excellent low temperature flexibility, making it ideal for applications in climates with extreme temperature variations. It is composed of carefully selected asphalts and blended with high quality styrene-butadiene-styrene rubber. Ram 306 is reinforced with a high-strength fiberglass mat and a ceramic granulated surface, both of which give the membrane excellent UV protection. Ram 306 incorporates a smooth and even application of fine slag to prevent blocking of rolls and to provide a smooth, acceptable application surface. Ram 306 can be applied by using hot asphalt or by using any Barrett-approved elastomeric cold process adhesive.



Ram 306-FR

Fire-Rated Fiberglass Reinforced SBS Modified Granular Cap Sheet

Ram 306 is a fire-resistant, granule surfaced, premium SBS (Styrene-Butadiene-Styrene) mop or cold applied membrane. Manufactured with a fiberglass mat that is saturated and coated with high quality, asphaltic bitumen and SBS elastomers for a durable, flexible and easily maintainable membrane. Ram 306-FR is designed for use as a cap sheet in modified bitumen and hybrid built-up roof systems.

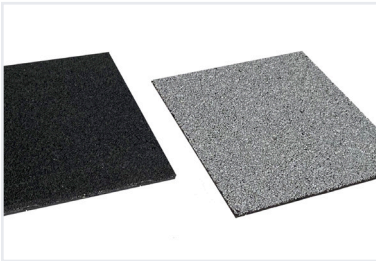

Ram 307-TA

Torch-Applied Polyester Reinforced SBS Modified Granular Cap Sheet

Ram 307-TA is a superior SBS modified bitumen roofing membrane with fire retardant additives and reinforced with a non-woven polyester reinforcement that provides excellent flexibility, dimensional stability, tear, and puncture resistance. The proprietary SBS compound offers superb waterproofing and weathering physical properties. Ram 307-TA has a granular top surface in black or white, as well as a sand or burn-off film bottom surface. Application methods include heat welding when a film bottom surface is selected & hot asphalt or cold adhesive when the membrane is sand backed.



Ram 40

Heavy-Duty Polyester/Fiberglass Composite Reinforcement Fabric

Ram 40 is a trilaminate polyester and fiberglass reinforcement sheet designed for use in both cold and hot applied built-up membrane assemblies. Ram 40 is heavily saturated and coated with a weathering grade asphalt for added thickness and protection. This heavy duty reinforced composite sheet provides high tensile and puncture resistance while remaining flexible enough to conform to minor irregular roof deck surfaces.



Ram 100TC

Heat-Welded SBS Modified Asphalt Protective Base Sheet

Ram 100TC is made from specially selected asphalt and high-quality SBS polymers that are blended using equipment designed specifically for polymer modifying asphalts. Ram 100TC is reinforced with high-strength fiberglass mat which yields excellent membrane dimensional stability and ease of application. Ram 100TC is designed as a base sheet for Ram QuikFlash® PMMA Roof Coating & Flashing Systems. It should not be used as the cap sheet in any roof system and must be installed by heat-welding.

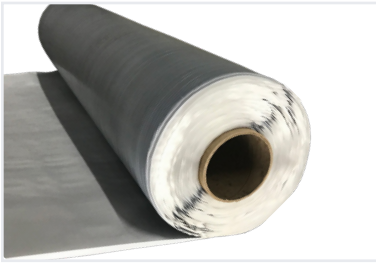

RamShield 60 (60 mil)

Woven Polyethylene Self-Adhering Below-Grade Sheet Membrane

RamShield® 60 is a 60-mil self-adhering membrane for above and below-grade waterproofing. It features a woven polyethylene membrane coated on both sides with a uniquely engineered waterproofing blend. It provides a self-adhered waterproofing membrane in above and below grade applications. RamShield® 60 can be used for a variety of above and below-grade waterproofing applications, including concrete foundation walls, foundation waterproofing, plaza decks, balconies, tunnels, parking decks, breezeways, and more.



PolyFelt 125VP

Lightweight Spunbond Polyester Reinforcement Fabric

PolyFelt 125VP is a 16-mil lightweight thermally-bonded spunlaid non-woven polyester fabric reinforcement. PolyFelt 125VP can be installed as a reinforcement fabric between the first and second layers in RamTough 250 & KLB-100 applications.



PolyFelt 265VP

Heavy-Duty Spunbond Polyester/Fiberglass Reinforcement Fabric

PolyFelt 265VP is a spunbond polyester reinforcement fabric with longitudinal fiberglass strand reinforcement specifically engineered for premium high performance waterproofing and roofing. The material provides very high puncture and tear-resistant fabric properties with an excellent strength-to-weight ratio. PolyFelt 265VP can be installed as a ply sheet for built-up roofing systems, as well as a backer sheet for composite base flashing systems and repair work on bituminous roofing systems.



PolyFelt 3.5

Lightweight Spunbond Polyester Protective Filter Fabric

PolyFelt 3.5 is a lightweight continuous spunbond filament polyester geotextile fabric that provides excellent strength-to-weight ratio. PolyFelt 3.5 is installed on the insulation to protect it from UV degradation, ballast and growing medium entering the joints and potentially clogging drain.



PolyFelt EX9 (9 oz)

Extensive Polypropylene Polyester Protective Fleece

PolyFelt EX9 (9 oz) is a 100% recycled polypropylene polyester fleece designed to store water & nutrients, protect the roof membrane and/or root barrier from damage, and separate materials of incompatible substrates within extensive green roofing systems. PolyFelt EX9 has a mass/structure and water holding capacity designed with the dead load weight and plant palettes of the extensive roof system in mind to give the perfect balance of water holding capacity and protection.

- Separates materials of incompatible substrates from one another.



Flashings & Accessories



Black Pearl® Butyl Tape

Polyester Reinforced SBS Modified Asphalt Protective Base Sheet

Black Pearl® Butyl Tape compound is a non-hardening butyl rubber extruded tape sealant. It will remain flexible and develop an immediate and permanent bond to a wide range of metal, concrete, glass and most plastics substrates.



RamFlash 327 HDR

Heavy-Duty Uncured Neoprene Sheet Flashing

RamFlash 327 HDR is a 60 mil heavy-duty uncured neoprene flashing material to be used in conjunction with RamTough 250 and RamTough KLB-100. It is designed to be flexible and conform to irregular surfaces and shapes, curing in place after installation.



RamSeal 40 (40 mil)

Woven Polyethylene Self-Adhering Sheet Flashing

RamSeal 40 is a 40 mil self-adhering composite membrane that combines high strength, low temperature adhesion and high temperature stability into a superior barrier to limit air and moisture transmission. The proprietary, modified asphalt offers the waterproofing effectiveness of traditional modified bitumen products with low temperature adhesion. RamSeal 40 can be used to prevent vapor and air transmission through masonry walls, construction joints, and door/window fittings.

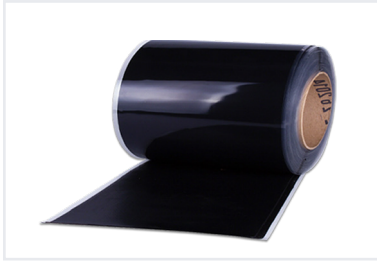

Ram QuikFlash® PVC

Non-Reinforced Polymeric Elastomeric Vinyl Sheetting

Ram QuikFlash® PVC-20 is a 20-mil non-reinforced polyvinyl chloride (PVC) sheet membrane composed of elastomeric substances which have been reduced to a thermoplastic state and formed into a continuous waterproofed sheet. Ram QuikFlash® PVC is available in both 20-Mil and 30-Mil thicknesses. When the use of prefabricated accessories is not feasible, Ram QuikFlash® PVC can be used to create inside and outside corners, field-fabricated pipe flashings, curb corners, and scuppers.



Ram QuikFlash® EPDM

High-Strength Synthetic Rubber Elastomeric Thru-Wall Flashing

Ram QuikFlash® EPDM is a high-strength synthetic rubber sheet that provides a highly durable, flexible, and economical solution for single-ply EPDM restoration and flashing. Available in 40 mil and 60 mil rolls, Ram QuikFlash® EPDM also offers an ideal solution for controlled roofing applications, like thru-wall flashing, thanks to its durability under harsh, exposed roofing conditions. Ram QuikFlash® EPDM offers superior tear and puncture resistance, as well as resistance from decomposition due to UV or ozone exposure. Additionally, it will not drool in high temperatures and remains flexible in temperatures as low as -49° F.



Neoprene Pipe Boots

High-Strength Synthetic Rubber Elastomeric Thru-Wall Flashing

Barrett Neoprene Pipe Boots offer an economical flashing designed for hot and cold applied rubberized asphalt roofing and waterproofing systems. These units will accommodate pipe sizes: Medium Pipe Boot = 1" - 6" ; Large Pipe Boot = 8" - 12". The conically shaped steps of the Barrett pipe flashing will securely seal all pipes, and the large, double-thick molded rib at the top of each step offers supreme tear resistance and reinforcement, as well as a convenient cutting guide.



= Greenroof-Roofscapes® Product

TB Termination Bars

Stainless Steel/Aluminum Flashing Termination Bars



TB-50

Channel Termination Bar

TB-50 is a channel termination bar used for edge or vertical parapet wall terminations. Each TB-50 termination bar is 1" wide and 10" long and is compatible with all flashings.



TB-75

Lip Termination Bar

TB-75 is a termination bar used at top of flashing to secure it to the backup. Additionally, it has a 3/8" flange on top for easy caulking. TB-75 is compatible with all flashings.



TB-125

Flat Termination Bar

TB-125 is a flat termination bar used at top of flashing to secure it to the backup. TB-125 is compatible with all flashings.

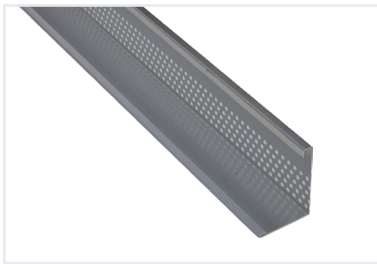

Roofscape® Edge

Aluminum Edging for Extensive Vegetated Roofs

Roofscape® Edge is designed as a definite boundary between gravel/paver and growth media within extensive vegetated roofs that allows the flow of water but not of the substrate. Available in 4", 5", and 6", these aluminum edges utilize a "smooth slide" design to make secure, invisible connections that prevent overly moist media conditions around the perimeter or in transition areas of the roof, thus preventing anaerobic growing conditions. They also have prefabricated corners for ease of installation.

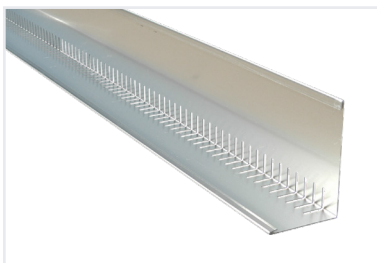

Roofscape® Edge+

Aluminum Edging for Semi-Intensive Vegetated Roofs

Roofscape® Edge+ is designed as a definite boundary between gravel/paver and growth media within semi-intensive vegetated roofs that allows the flow of water but not of the substrate. Available in 9" and 12", these aluminum edges utilize a "smooth slide" design to make secure, invisible connections that prevent overly moist media conditions around the perimeter or in transition areas of the roof, thus preventing anaerobic growing conditions. They also have prefabricated corners for ease of installation.

EDGE MALE



EDGE CORNER



EDGE+ MALE

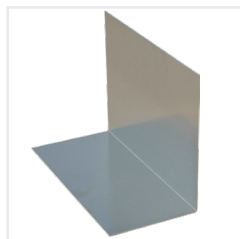

EDGE+ CORNER

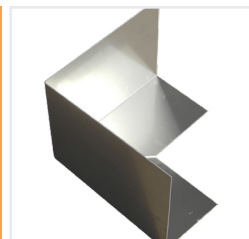



Preformed Drainage



RamDrain EN 36R (0.45")

Prefabricated Entangled Net Composite Drainage Mat

RamDrain EN 36R is a prefabricated entangled net composite drain 0.45" thick, "zig-zag" geometric patterned core, drainage mat with a layer of non-woven geotextile on both front and back of the product. RamDrain EN 36R-045 has a 3-inch (76.2 mm) fabric flange beyond the core to provide overlaps with adjacent drainage courses. RamDrain EN 36R-045 is designed to eliminate hydrostatic pressure for plazas decks, foundation walls, balconies and planters in both horizontal and vertical applications.

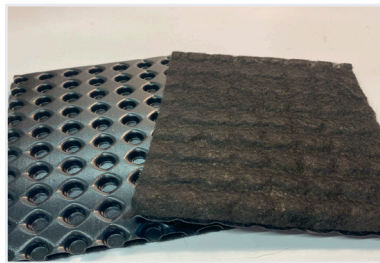

RamDrain DD 025 (0.25")

Prefabricated Dimpled Composite Drainage Mat

RamDrain DD (Dimpled Drain) 025 is a high-performance two-layer drainage sheet that is engineered to relieve hydrostatic pressure by creating a channel for liquid water. The first layer is constructed of a high strength, cuspated (dimpled) polymetric sheet designed to provide superior compressive strength. Adhered to the high strength, cuspated polymer base is a nonwoven filter fabric. The non-woven spunbonded filter fabric is designed to promote high water flow while not allowing dirt and silt to penetrate the drainage channel.

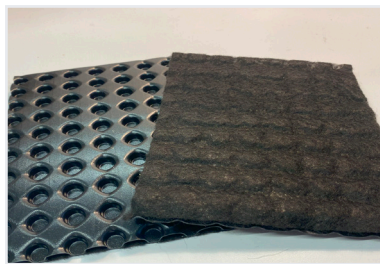

RamDrain DD 025 HS (0.25")

High Strength Prefabricated Dimpled Composite Drainage Mat

RamDrain DD (Dimpled Drain) 025 HS is a high-performance two-layer drainage sheet with extremely high compression strength that is engineered to relieve hydrostatic pressure by creating a channel for liquid water. The first layer is constructed of a high strength, cuspated (dimpled) polymetric sheet designed to provide superior compressive strength. Adhered to the high strength, cuspated polymer base is a nonwoven filter fabric. The non-woven spunbonded filter fabric is designed to promote high water flow while not allowing dirt and silt to penetrate the drainage channel.



RamDrain DD 040 F (0.40")

Prefabricated Dimpled Composite Self-Adhering Drainage Mat

RamDrain DD 040F is composed of a dimpled polymeric HIPS core with a nonwoven polypropylene geotextile fabric bonded to the dimple side and a polymeric film bonded to the back side. The geotextile allows water to pass through while retaining backfill materials. The solid core allows water collection from one side and provides a continuous flow for drainage. The polymeric backing film provides system compatibility with softer waterproofing membranes. RamDrain DD 040F is an economical solution for single-sided subsurface drainage applications requiring high strength, high flow capacity, and additional protection for softer waterproofing membranes.



= Greenroof-Roofscapes® Product

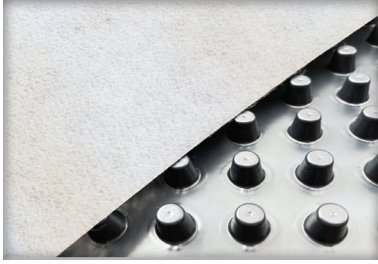

RamDrain DD 040 HS (0.40")

High-Strength Prefabricated Dimpled Composite Drainage Mat

Greenroof-Roofscapes® RamDrain DD-040HS is designed for drainage beneath accessible areas that do not need water storage and on vertical building components. It is a composite drainage layer consisting of a three-dimensional drainage core and a filter fabric bonded to the core, preventing intrusion of the overburden into the drainage channels. It retains soil or sand particles as well as freshly placed concrete allowing filtered water to pass through to the drainage core. It is typically used in areas necessitating a moderate compressive strength material for drainage, specifically for low load pedestrian accessibility for pavers, concrete or asphalt walkways, and patios.

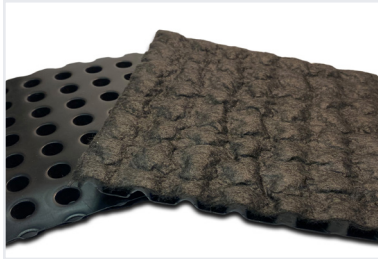

RamDrain DD 050 (0.50")

Prefabricated Dimpled Composite Drainage Mat

RamDrain DD (Dimpled Drain) 050 is a high-performance two-layer drainage sheet with superior flow rate that is engineered to relieve hydrostatic pressure by creating a channel for liquid water. The first layer is constructed of a high strength, cusped (dimpled) polymetric sheet designed to provide superior compressive strength. Adhered to the high strength, cusped polymer base is a nonwoven filter fabric. The non-woven spunbonded filter fabric is designed to promote high water flow while not allowing dirt and silt to penetrate the drainage channel.



RamDrain DD 050 HS (0.50")

High-Strength Prefabricated Dimpled Composite Drainage Mat

RamDrain DD (Dimpled Drain) 050 HS is a two-part prefabricated geocomposite drain consisting of a formed polystyrene core that is covered on one side with woven monofilament filter fabric. This fabric allows water to pass into the drain core while restricting the movement of soil particles which might clog the core, allowing the water to flow to designated drainage exits. RamDrain DD 050 HS with ½" height can move more drainage water per foot width than a layer of stone which is 1' wide and 180" high. RamDrain DD 050 HS is designed for horizontal applications.

Did You Know?

In addition to numerous LEED certifications & other achievements, a total of **FOUR** projects utilizing Barrett's Greenroof-Roofscapes® have been awarded the prestigious **GRCH "Award of Excellence"** due to their excellent waterproofing capabilities, environmental impact, aesthetic, and overall system design.





Retention & Aeration



Roofscape® Air Mat (0.25")

Prefabricated Entangled Net Composite Drainage Mat

Roofscape® Air Mat is a prefabricated entangled net composite drain 0.25" thick, "zig-zag" geometric patterned core, drainage mat with a layer of non-woven geotextile on both front and back of the product. Roofscape® Air Mat has a 3-inch (76.2 mm) fabric flange beyond the core to provide overlaps with adjacent drainage courses. Roofscape® Air Mat is designed to eliminate hydrostatic pressure for plazas decks, foundation walls, balconies and planters in both horizontal and vertical applications.



Roofscape® RND 1.0 (1")

Semi-Rigid Waffled HDPE Retention & Drainage Mat

Roofscape® RND 1.0 (Retention & Drainage) is designed for extensive vegetated roofs requiring moderate water storage. It is a semi-rigid waffled plastic sheet that retains water within pockets on the upper side, making water available to vegetation. It has drill holes to drainage channels for diffusion & irrigation, and it channels surplus water through its bottom-sided canal system for secure drainage. Roofscape® RND 1.0 allows for the incorporation of a complete array of zone appropriate drought tolerant plantings in a less than 6" depth assembly.



Roofscape® RND 1.0 HS (1")

High-Strength Semi-Rigid Waffled HDPE Retention & Drainage Mat

Roofscape® RND 1.0 HS (Retention & Drainage) is designed for vegetative roofs with high pressure loads using a complete array of zone appropriate drought tolerant plantings. It is a semi-rigid waffled plastic sheet that retains water within pockets on the upper side, making water available to vegetation. It has drill holes to drainage channels for diffusion & irrigation, and it channels surplus water through its bottom-sided canal system for secure drainage. Roofscape® RND 1.0 HS allows for the incorporation of a complete array of zone appropriate drought tolerant plantings.



Roofscape® RND 1.6 (1.6")

High-Strength Semi-Rigid Waffled HDPE Retention & Drainage Mat

Roofscape® RND 1.6 (Retention & Drainage) is designed for semi-intensive vegetated roofs requiring water storage. It is a semi-rigid waffled plastic sheet that retains water within pockets on the upper side, making water available to vegetation. It has drill holes to drainage channels for diffusion & irrigation, and it channels surplus water through its bottom-sided canal system for secure drainage. Roofscape® RND 1.6 allows for the incorporation of a complete array of zone appropriate perennials and ornamental grasses in a 6" - 12" depth assembly.

 = **Greenroof-Roofscapes® Product**



Roofscape® RND 2.4 (2.4")

High-Density Waffled HDPE Retention & Drainage Panel

Roofscape® RND 1.6 (Retention & Drainage) provides water storage for intensive roofs with large plant palettes. It is a high-density waffled plastic panel that retains water within pockets on the upper side, making water available to vegetation. It has drill holes to drainage channels for diffusion & irrigation, and it channels surplus water through its bottom-sided canal system for secure drainage. Roofscape® RND 2.4 allows for the incorporation of a complete array of zone-appropriate, drought-tolerant plantings in a greater than 12" depth assembly.



RamDrain 1241 (0.50")

Perforated Composite Water Retention & Drainage Board

RamDrain 1241 is a 1/2" perforated composite polymeric drainage board with fabric on both sides. RamDrain 1241 is designed to be used in vegetated greenroof and planter configuration, the fabric cover allows excess water to flow from the growing medium into the water storage cups, while preventing the growing medium sediment from entering. The design is able to retain 0.06 gal/ft².



RamDrain 2451 (1")

Perforated Composite Water Retention & Drainage Board (1")

RamDrain 2451 is a 1" perforated composite polymeric drainage with fabric on both sides. RamDrain 2451 is designed to be used in vegetated greenroof and planter configuration, the fabric cover allows excess water to flow from the growing medium into the water storage cups, while preventing the growing medium sediment from entering. The design is able to retain 0.11 gal/ft².



Baltimore Convention Center

Baltimore, MD | 28,000 sq/ft

Project:
Baltimore Convention Center

Location:
Baltimore, MD

Job Size:
28,000 sq/ft

Client/Owner:
City of Baltimore

Architects:
Gant Brunnet Architects

Contractor:
National Roofing Co.

Product/System:
Greenroof-Roofscape® with RamTough 250

Green Roof Type:
+ Extensive
+ Intensive

Slope:
1%



Root Barriers



Ram RB 20 (20 Mil)

Polyethylene Root Barrier

Ram RB 20 is a 20-mil polymeric sheet that effectively arrests root penetration and redirect roots to a horizontal growth plane, helping lock in vegetation and increasing resistance to wind up-lift forces.



Ram RB 30 (30 Mil)

Polyethylene Root Barrier

Ram RB 30 is a 30-mil polymeric sheet that effectively arrests root penetration and redirect roots to a horizontal growth plane, helping lock in vegetation and increasing resistance to wind up-lift forces.



Ram RB 40 (40 Mil)

Heavy-Duty Polyethylene Root Barrier

Ram RB 40 Root Barrier is a heavy duty, 40-mil linear polyethylene sheet which has been successfully established as an effective root barrier under severe conditions. Ram RB 40 Root Barrier contains virgin resins which does not become brittle or age prematurely. A typical carbon black content of 2.4% provides excellent protection from UV exposure and harsh weather conditions.



Ram RB 25 Seam Tape

Single-Sided Elastomeric Adhesive Root Barrier Seam Tape

Ram RB 25 Seam Tape is an elastomeric single-sided adhesive tape used to seal the seams of the Ram RB series of root barriers. The black polymer backing, and very aggressive adhesive is specifically formulated to provide maximum performance in green roof and planter box applications.

 = Greenroof-Roofscapes® Product



Ram RootProtect

Polyester Reinforced Asphalt Granular Cap Sheet + Root Protection

Ram RootProtect is a heavy-duty, rubberized asphalt sheet that is specially formulated with a factory-applied root growth regulator. The sheet is polyester reinforced and has a granule surfacing. Ram RootProtect is specifically designed to be embedded into Barrett's RamTough 250 roofing membrane when installed in a Greenroof-Roofscapes® Assembly. Ram RootProtect provides protection to the membrane from mechanical damage as well as damage due to penetration by roots.



Coco Erosion Control Blanket

100% Biodegradable Double-Sided Coconut Erosion Control Blanket

Coco Erosion Control Blanket is an FHWA Type IID temporary erosion control blanket that is used to control erosion of Greenroof-Roofscapes® media and plantings on flat and low-sloped installations. It is composed of 100% Coconut/Coir Fiber distributed evenly between two layers of biaxially oriented Jute netting. The matrix is mechanically bonded (stitched) using biodegradable thread. Coco Erosion Control Blankets are designed to protect slopes and channels from erosive forces while allowing the passage of sunlight and moisture, providing the optimum environment for plant root development.



Roofscape® Liquid Erosion Control

Cross-Linked Polymer Hydrospray Erosion Control Liquid

Roofscape® Liquid Erosion Control is a breathable, water-absorbing hydrospray fluid that is utilized for the stabilization of low slope green roofs, bioinfiltration swales and standard roadside embankments. Upon application, the liquid bonds with growth media to create a porous surface which accepts rain water but resists wind erosion. Unlike most hydrospray products, Roofscape® Liquid Erosion Control won't degrade over ten or so precipitation or irrigation events. It requires very little water for activation (about 5-10 gal / 100 sq ft) and will begin to gel within 12 hours.

Project:
Willis Tower Repositioning

Location:
Chicago, IL

Job Size:
87,391 sq/ft

Client/Owner:
EQ Group

Architects:
Gensler

Contractor:
Kedmont
Waterproofing

Product/System:
Greenroof-Roofscapes®
with RamTough 250

Green Roof Type:

- + Insulation/Pavers
- + Insulation/Slab
- + Insulation/Turf
- + Insulation/Alum. Skirt



Willis Tower Repositioning
Chicago, IL | 87,391 sq/ft



Coatings & Mastics



Ram Primer & Surface Conditioner

General Utility Asphaltic Primer & Surface Conditioner

Ram Primer & Surface Conditioner is a general utility asphaltic prime coat for both porous and non-porous surfaces in the application of RamTough 250 and/or RamTough KLB-100. It can be brushed, rolled, or sprayed and is typically used on concrete, gypsum, brick, masonry, metal, and aged asphalt.



RamShield Adhesive

Solvent Release Adhesive

RamShield Adhesive is a fast-drying solvent release adhesive that is formulated to have outstanding performance with all Barrett RamShield Membrane products. Designed to require a minimum amount of mixing before applications, RamShield Adhesive will also work with most asphalt based waterproofing membranes.



Ram Mastic

Premium Rubberized Asphalt Roof Cement

Ram Mastic is trowel grade, single component, Kraton® SBS rubber modified asphalt which forms a highly elastomeric sealant material. Ram Mastic has superior elongation properties, remains pliable at cold temperatures and has excellent weathering properties. It is recommended on any applications where a high quality cold applied, elastomeric material is required. Used for detailing, seam seal and repair of asphaltic material. Ram Mastic is designed to be used with RamTough 250, RamTough KLB-100, and Black Pearl® on T-joints, overlaps in detail areas, and as a repair mastic.



Ram Ultra-White® Primer

Water-Based Acrylic Primer

Ram Ultra-White® Primer is a clear, water based acrylic primer formulated to provide excellent adhesion properties to various surfaces. Ram Ultra-White® Primer is specifically design to be used as a primer coat for Barrett Ultra-White® acrylic coating for increased adhesive bonding to bituminous roof membranes, metal, concrete block, concrete, brick and stucco surfaces.



Ram Ultra-White® Coating

Energy-Star® Rated Elastomeric Acrylic Roof Coating

Ram Ultra-White Coating is a co-polymer elastomeric water-based emulsion that provides excellent UV protection, weatherability, elasticity, and substantial reduction of roof surface temperatures and thermal stresses, significantly increasing indoor comfort and saving cooling costs. Its brilliant white color offers excellent reflectivity, earning it an Energy Star® rating and LEEDS credits. Ram Ultra-White® has proven itself as an excellent surfacing for both new and weathered built-up and modified bitumen roof systems.



Ram Ultra-Silver® Coating

Energy-Star® Rated Rubberized Aluminum Roof Coating

Ram Ultra-Silver® is made of the highest quality SBS polymer-modified asphalt, premium aluminum pigment and refined solvents. In addition to providing excellent UV protection, elasticity, and weatherability, aluminum flakes found in the pigment come to the surface when applied, providing a highly reflective metallic shield that significantly reduces surface temperatures and thermal movement. Ram Ultra-Silver has proven itself as an excellent surfacing for both new and weathered asphalt built-up and modified bitumen roof systems.



CP-80 Cold Process Adhesive

High-Strength SBS Polymer-Modified Cold Process Adhesive

CP 80 Cold Process Adhesive is a high-strength SBS Polymer-modified cold process adhesive formulated for use in coating metal roofing and the construction of "Cold Process" built-up roof membrane systems. This unique formulation offers excellent adhesion and elongation properties and is an alternative solution when a hot applied membrane system is not practical. CP-80 Cold Process Adhesive is compatible with several Barrett fiberglass and polyester reinforcement options and is fully waterproof after cure. This material is "Asbestos Free"



HyppoCoat PC (Primer)

Two-Component Solvenated Epoxy-Polyamine Primer

HyppoCoat PC is a two component, solvenated, epoxy-polyamine liquid-applied primer with unique penetrating characteristics. This primer is recommended for use with HyppoCoat 100 and HyppoCoat 250 Trafficable Waterproofing Systems on metal flashings and other medium to heavy duty trafficable areas in outdoor applications. Two versions of this primer can be used— HyppoCoat PC (100 VOCs) and HyppoCoat PC+ (250 VOCs).



HyppoCoat TC (Top Coat)

Two-Component High Solids Aliphatic Elastomeric Top Coat

HyppoCoat TC is a two-component, very high solids, aliphatic hybrid elastomeric top coat. HyppoCoat TC is odor friendly, fast-setting, rapid-curing, and can be applied to properly prepared interior or exterior concrete, plywood and metal surfaces. It is suitable for single or multiple applications in temperatures as low as 20°F (-6.7°C).



Liquid Flash 100 (100% Solids)

High-Performance Single Component Joint Sealant

Liquid Flash 100 (100% Solids) is a high-performance interior/exterior joint sealant for use in both moving and non-moving joint applications. Liquid Flash 100 provides a long-lasting weathertight seal to a variety of building substrates.



KeeneSeal 100

Single-Component Multi-Purpose Elastomeric Sealant

KeeneSeal 100 is a one component, fast grab, multipurpose silyl-terminated polyether (hybrid) elastomeric sealant. When fully cured, this unique VOC compliant formula offers spectacular stress-free adhesion to PVC, concrete, masonry, painted surfaces, USB, plywood, metal, and other common substrates. This product is specifically formulated to offer all-weather performance to meet today's green building standards.



Barrett Products & Systems

Recycled Content

Many products supplied by The Barrett Company contain recycled materials which can be considered recyclable thereafter. This information is offered as a quick reference guide to recycled content. For practical reasons some products will not perform to their optimum using recycled materials. Some products require components which are not available in a recycled form. Barrett does everything possible to include recycled materials in its products from manufacturing to packaging, provided they do not compromise the quality and long-term performance of the material.

<p>RamTough 250 Manufactured in Allentown, PA</p> <p>7% Recycled tire rubber crumb by weight, pre-mixed, >25% post-mix; Post-Consumer; >25% asphalt by weight, Post-Industrial; 20% Regionally Extracted</p> <p>Origin of Raw Material:</p> <ul style="list-style-type: none"> Asphalt - Warren, PA Process Oil - Vicksburg, MS Polymer - Baytown, TX & Brownsville, TX Calcium Carbonate - Hummelstown, PA Recycled tire rubber crumb - Trainer, PA 	<p>RamDrain EN 36R Manufactured in Cleveland, OH</p> <p>31% Post-Industrial Recycled Content by weight</p> <p>Origin of Raw Material:</p> <ul style="list-style-type: none"> Cleveland, OH 	<p>Ram Primer & Surface Conditioner Manufactured in Westfield, NJ</p> <p>>50% Recycled Asphalt Content, Pre-Consumer</p> <p>Origin of Raw Material:</p> <ul style="list-style-type: none"> Perth Amboy, NJ
<p>PolyFelt 125VP Manufactured in Enka, NC</p> <p>10% Recycled Content by weight; Post-Consumer</p> <p>Origin of Raw Material:</p> <ul style="list-style-type: none"> North Carolina South Carolina Texas 	<p>RamDrain 630 Manufactured in Carson City, NV & Monroe, NC</p> <p>79% Pre-Consumer Recycled Content by weight</p> <p>Origin of Raw Material:</p> <ul style="list-style-type: none"> Monroe, NC 	<p>Ram Mastic Manufactured in Westfield, NJ</p> <p>>50% Recycled Asphalt Content</p> <p>Origin of Raw Material:</p> <ul style="list-style-type: none"> Perth Amboy, NJ
<p>RamFlash 327 HDR Manufactured in Wayne, NJ</p> <p>10% Recycled Content by weight; Post-Consumer</p> <p>Origin of Raw Material:</p> <ul style="list-style-type: none"> Wayne, NJ 	<p>Ram Aeration Mat 600 Manufactured in Enka, NC</p> <p>0% Recycled Content</p> <p>Origin of Raw Material:</p> <ul style="list-style-type: none"> Enka, NC 	<p>Barrett Neoprene Pipe Boots Manufactured in Bensenville, IL</p> <p>0% Recycled Content</p> <p>Origin of Raw Material:</p> <ul style="list-style-type: none"> Bensenville, IL
<p>RamDrain 1241 Manufactured in Monroe, NC</p> <p>66% Pre-Consumer Recycled Content by weight</p> <p>Origin of Raw Material:</p> <ul style="list-style-type: none"> Monroe, NC 	<p>PolyFelt 3.5 Manufactured in Athens, GA</p> <p>0% Recycled Content</p> <p>Origin of Raw Material:</p> <ul style="list-style-type: none"> Athens, GA 	<p>GR Edging & Drain Access Box Assembled in Evanston, Des Plaines, & Wauconda, IL</p> <p>Aluminum; 41% Recycled Content by weight Stainless Steel; 80% Recycled Content by weight</p> <p>Origin of Raw Material:</p> <ul style="list-style-type: none"> Oswego, NY
<p>RamDrain 2451 Manufactured in Monroe, NC</p> <p>75% Pre-Consumer Recycled Content by weight</p> <p>Origin of Raw Material:</p> <ul style="list-style-type: none"> Monroe, NC 	<p>Ram RB20, RB30, RB40 Manufactured in Cleveland, OH</p> <p>0% Recycled Content</p> <p>Origin of Raw Material:</p> <ul style="list-style-type: none"> Cleveland, OH 	<p>Ram 200, 201, 203, 306 Manufactured in Wadsworth, OH</p> <p>>50% Recycled Asphalt Content; 20% Regionally Extracted</p> <p>Origin of Raw Material:</p> <ul style="list-style-type: none"> Wadsworth, OH Vancouver, BC, Canada
<p>Ram Coco Erosion Control Blanket Manufactured in Bernville, PA</p> <p>0% Recycled Asphalt Content</p> <p>Origin of Raw Material:</p> <ul style="list-style-type: none"> Coir - SE Asia Netting & Thread - North Carolina 	<p>Extruded Polystyrene Insulation:</p> <ul style="list-style-type: none"> Styrofoam™ by DuPont Foamular™ by Owens Corning 	

Please Note: All items listed above contain 0% regionally extracted content by weight. All materials are obtained offsite and brought to the facility for manufacturing.

Insulatio

The Ultimate & Complete Barrett Single System Warranty

THE BARRETT GUARANTEE

Unlike other manufactures, Barrett believes that it is our responsibility to focus on what we do best—To provide our customers the most superior waterproofing products on the market. The assembly begins with choosing the correct Barrett system for the job based on the project & application requirements and ensuring the assembly comes with a complete single source warranty.

Our joint agreements with some of the industry's top suppliers of insulation, pavers, soil & growth media, and more allows us to offer a **Complete Single Source Warranty** for our clients with the flexibility to choose the products of their choice without having to be held to just one product offering. All these products and manufacturers are of the highest standards and quality. They all have been tested and proven to be warranted as part of the Barrett System.



This single source warranty puts the liability on us, allowing our clients to rest easy knowing they chose Barrett as their system.



Insulation & Pavers

Warranty Partners

Below are all of the partners with products and/or systems that can be chosen as part of our complete system warranty:

INSULATION		
		
PAVERS		

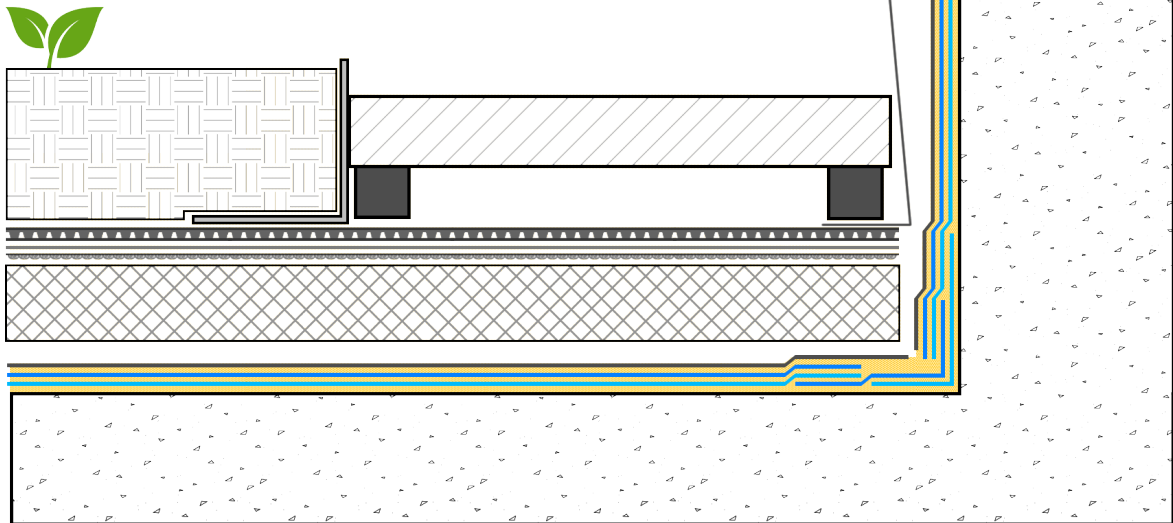

For specific info on our warranties or special overburden products, please contact Barrett directly.

“Warranty”

(noun) – a written guarantee of the integrity of a product and of the maker’s responsibility for the repair or replacement of defective parts

Platinum Plus Labor and Material warranties can include insulation, concrete pavers, pedestals, Greenroof-Roofscapes® components, sheet metal flashings, and other specialized roofing components, in addition to the waterproofing membrane and membrane flashing.

Limited warranties are available for Barrett materials (Material Warranty) and for both material and workmanship (Labor and Material Warranty).

Important considerations for warranties include:

- Scope of Coverage**
- Monetary Limits on Remedy**
- Exclusions**
- Nullification Provisions**
- Determination of Warranty Applicability**
- Maintenance Requirements**

Barrett warranted systems must:

- Be installed by a Barrett Approved Contractor**
- Follow Barrett specifications and details**
- Be inspected and accepted by Barrett**
- Be properly maintained by simple, straightforward procedures**

A warranty has significant legal consequences; therefore, all parties should understand the document at the outset of a construction project to preclude subsequent misunderstandings. Building Owners should review any warranty document with appropriate counsel.

Typical Labor & Material Limited Warranties

RamTough 250

RT250 Below-Grade & Foundation	20 Years
RT250 Typical Waterproofing	20 Years
RT250 Protected Membrane Roof	30 Years
RT250 Parking & Bridge Deck	10 Years
RT250 Greenroof-Roofscapes®	20 Years

HyppoCoat GC

HGC (90 mils) • 1P • HGC (125 mils)	10 Years
HGC (120 mils) • 1P • PC • DD	10 Years
HGC (90 mils) • 1P • PC • DD	10 Years
HGC (60-90 mils) • DD	10 Years
HGC (60-90 mils) • PC	5 Years

Black Pearl®

Black Pearl® Below-Grade & Foundation	20 Years
Black Pearl® Typical Waterproofing	20 Years
Black Pearl® Protected Membrane Roof	25 Years
Black Pearl® Parking & Bridge Deck	10 Years
Black Pearl® Greenroof-Roofscapes®	20 Years

HyppoCoat 100/AP100

HC100 Trafficable Membrane (Extended)	15 Years
HC100 Vehicular Membrane	10 Years
HC100 Balcony/Deck Membrane	10 Years
HC100 Pedestrian Membrane	10 Years
HC100 Pedestrian Membrane (Recoat)	5 Years

RamTough KLB-100

KLB-100 • 4P • I • GS	30 Years
KLB-100 • 3P • I • GS	20 Years
KLB-100 • 2P • I • GS	15 Years
KLB-100 • 1P • RR • SC	5 Years

HyppoCoat 250

HC250 Trafficable Membrane (Extended)	15 Years
HC250 Vehicular Membrane	10 Years
HC250 Pedestrian Membrane	10 Years
HC250 Pedestrian Membrane (Recoat)	5 Years

Ram Cold Tar® Plus

Roof Restoration & Repair

RCT • 3/40 • RR • I • GS	10 Years
RCT • 3/40 • RR • I • SC	5 Years
RCT • B • 1/40 • RESTO • _____	10 Years
RCT • RESTO • _____	5 Years

Cold Process Built-Up Roofing

RCT • 5/40 • I • GS	25 Years
RCT • 4/40 • I • GS	20 Years
RCT • 3/40 • I • GS	15 Years
RCT • 3/40 • I • SC	15 Years

Greenroof-Roofscapes®

RT250 Greenroof-Roofscapes®	Up to 20 Years
Black Pearl® Greenroof-Roofscapes®	Up to 20 Years

— LIMITED WARRANTY —

Barrett warrants its Products to be free of defects in materials, but makes no warranty as to appearance or color. Since methods of application and on-site conditions are beyond our control and can affect performance, Barrett makes no other warranty, expressed or implied, including warranties of MERCHANTABILITY and FITNESS FOR A PARTICULAR PURPOSE, with respect to The Barrett Company, LLC. Barrett to replace or to refund the purchase price of the quantity of Barrett proven to be defective, and Barrett shall not be liable for any loss or damage.

Literature

Want to learn more about our individual products? All detailed product info, including technical & safety data sheets, installation instructions, architectural details, and more are available for download in the **Resource Library** of our website.

For questions regarding detailed specifications, application information, or any other general inquiries, please reach out to your local Barrett Technical Representative. You can also call us directly at **(800) 647-0100** or email us at **info@barrettroofs.com**

Videos

The success of a roofing & waterproofing system is ultimately reliant upon the accuracy of the installation.

To help ensure our applicators have the best resources available to ensure proper installation, Barrett has begun to develop a comprehensive **Video Library** with detailed, step-by-step instructions for each of our various systems.

All videos can be found on the **Videos** page of our website, as well as on our YouTube channel.



Black Pearl® Waterproofing System — Installation Demo —

Presented by Mike Eglin & Joseph Strickland

Approved Applicators

Quality products deserve quality application. To get the best performance from our roofing and waterproofing systems, the smart choice is to use a **Barrett Approved Applicator**. Applicators that want to be approved by Barrett must be committed to installing our products properly & successfully.

For more information or to apply to become a Barrett Approved Applicator, visit the **Become an Approved Applicator** page in the Resource Library of our website.

Webinars & Presentations

The Barrett Company, in collaboration with Keene Building Products and Dependable Floor Prep, are proud to present the “College of Knowledge,” a series of AIA accredited courses taught through free-to-attend live webinars.

Each course offers in-depth analysis and live presentations on current industry information that will benefit architects, engineers, contractors, distributors, & manufacturers alike. For all attendees, there is an open Q&A session with the host immediately following each course.

— Available Courses —



Green Roofs
Presented by
The Barrett Company



Plaza Deck Waterproofing
Presented by
The Barrett Company



Moisture Mitigation in Concrete
Presented by
Dependable Floor Prep



Healthy Walls: Rainscreen & Ventilation
Presented by
Keene Building Products



Introducing...

The Foreman's Guide For Roofing & Waterproofing

A monthly technical bulletin for architects, building owners, and applicators alike, **#TheForemansGuide** offers technical insight from experienced roofing & waterproofing applicators to ensure that every step of your project is carried out accurately, safely, and with the right tools for the job.

For more info or to subscribe, visit
barrettroofs.com/blog







- **ROOFING**
- **WATERPROOFING**
- **TRAFFICABLE DECK COATINGS**
- **GREENROOF-ROOFSCAPES®**
- **FLASHING & ACCESSORIES**
- **PAVERS & INSULATION**



**STAY
CONNECTED!**

 @thebarrettcompany

 @thebarrettcompany

 The Barrett Company, LLC

 The Barrett Company



(800) 647-0100



info@barrettroofs.com

barrettroofs.com